

# **Agilent Technologies N5242A Option H85**

## **User's and Service Guide**

### **Microwave PNA-X Series High Power Configurable Test Set**

PNA Series Network Analyzer On-line Help System

Application Note 1408-10



**Manufacturing Part Number: N5242-90008**

**Printed in USA: May 2008**

**Supersede: December 2007**

© Copyright 2007, 2008 Agilent Technologies, Inc. All rights reserved.

---

## Warranty Statement

THE MATERIAL CONTAINED IN THIS DOCUMENT IS PROVIDED “AS IS,” AND IS SUBJECT TO BEING CHANGED, WITHOUT NOTICE, IN FUTURE EDITIONS. FURTHER, TO THE MAXIMUM EXTENT PERMITTED BY APPLICABLE LAW, AGILENT DISCLAIMS ALL WARRANTIES, EITHER EXPRESS OR IMPLIED WITH REGARD TO THIS MANUAL AND ANY INFORMATION CONTAINED HEREIN, INCLUDING BUT NOT LIMITED TO THE IMPLIED WARRANTIES OF MERCHANTABILITY AND FITNESS FOR A PARTICULAR PURPOSE. AGILENT SHALL NOT BE LIABLE FOR ERRORS OR FOR INCIDENTAL OR CONSEQUENTIAL DAMAGES IN CONNECTION WITH THE FURNISHING, USE, OR PERFORMANCE OF THIS DOCUMENT OR ANY INFORMATION CONTAINED HEREIN. SHOULD AGILENT AND THE USER HAVE A SEPARATE WRITTEN AGREEMENT WITH WARRANTY TERMS COVERING THE MATERIAL IN THIS DOCUMENT THAT CONFLICT WITH THESE TERMS, THE WARRANTY TERMS IN THE SEPARATE AGREEMENT WILL CONTROL.

---

## DFARS/Restricted Rights Notice

If software is for use in the performance of a U.S. Government prime contract or subcontract, Software is delivered and licensed as “Commercial computer software” as defined in DFAR 252.227-7014 (June 1995), or as a “commercial item” as defined in FAR 2.101(a) or as “Restricted computer software” as defined in FAR 52.227-19 (June 1987) or any equivalent agency regulation or contract clause. Use, duplication or disclosure of Software is subject to Agilent Technologies’ standard commercial license terms, and non-DOD Departments and Agencies of the U.S. Government will receive no greater than Restricted Rights as defined in FAR 52.227-19(c)(1-2) (June 1987). U.S. Government users will receive no greater than Limited Rights as defined in FAR 52.227-14 (June 1987) or DFAR 252.227-7015 (b)(2) (November 1995), as applicable in any technical data.

---

## Safety Notes

The following safety notes are used throughout this document. Familiarize yourself with each of these notes and its meaning before performing any of the procedures in this document.

---

<b>WARNING</b>	<b>Warning denotes a hazard. It calls attention to a procedure which, if not correctly performed or adhered to, could result in injury or loss of life. Do not proceed beyond a warning note until the indicated conditions are fully understood and met.</b>
----------------	---

---

---

<b>CAUTION</b>	Caution denotes a hazard. It calls attention to a procedure that, if not correctly performed or adhered to, could result in damage to or destruction of the instrument. Do not proceed beyond a caution sign until the indicated conditions are fully understood and met.
----------------	---

---

---

## Definitions

- *Specifications* describe the performance of parameters covered by the product warranty (temperature –0 to 55 °C, unless otherwise noted.)
- *Typical* describes additional product performance information that is not covered by the product warranty. It is performance beyond specification that 80% of the units exhibit with a 95% confidence level over the temperature range 20 to 30 °C. Typical performance does not include measurement uncertainty.
- *Nominal* values indicate expected performance or describe product performance that is useful in the application of the product, but is not covered by the product warranty.
- *Characteristic Performance* describes performance parameter that the product is expected to meet before it leaves the factory, but is not verified in the field and is not covered by the product warranty. A characteristic includes the same guard bands as a specification.



## **N5242A Option H85**

Introduction	2
Description	2
N5242AH85 Basic Option Configuration	3
2-Port Default Configuration Includes the Following Options:	3
4-Port Default Configuration Includes the Following Options:	3
Operation	4
Maximum Power Levels	15
Making High Power Measurements With Option H85	20
Typeface Key Conventions	20
Initial Setup	21
Determining Power Levels	22
Additional Setup	24
Selecting Power Ranges and Attenuator Settings	25
Final Setup	29
Specifications	32
Service Information	32
Source Attenuator Operational Check	32
Replaceable Parts	33
Safety and Regulatory Information	35
Introduction	35
Cleaning the Instrument	35
Connector Care and Cleaning	35
Declaration of Conformity	35
Statement of Compliance	35
General Safety Considerations	36
Safety Earth Ground	36
Before Applying Power	36
Servicing	37
Regulatory Information	38
Instrument Markings	38
Compliance with Canadian EMC Requirements	39
Compliance with German FTZ Emissions Requirements	39
Compliance with German Noise Requirements	39
Electrostatic Discharge Protection	40
Agilent Support and Assistance	41
Service and Support Options	41
Contacting Agilent	41
Shipping Your Analyzer to Agilent for Service or Repair	41



---

# **N5242A Option H85**

## Introduction

This document describes the differences between the Agilent N5242A Option H85 and the N5242A Series Network Analyzer. For more technical specification information refer to Technical Specifications Agilent Technologies PNA Series Network Analyzers N5242A Options 200/219/224 (2-Port PNA-X) or Options 400/419/423 (4-Port PNA-X). The document part number is N5242-90007.

Information can be viewed or printed regarding the N5242A PNA Series Network Analyzer Data sheets, white papers, or manuals by visiting our web site at <http://www.agilent.com/find/pna> or by typing N5242A in the search field.

---

## Description

The Agilent N5242A Option H85 is a modified version of the standard N5242A PNA Series Network Analyzer. Option H85 is designed to permit insertion of high power amplifiers and other signal conditioning equipment to allow high power network measurements at RF levels up to 20 Watts (+43 dBm) from 10 MHz to 26.5 GHz. The Option H85 modification supplies extended power range attenuators *without* bias tees. This is similar to the N5242A-219 (add extended power range and bias-tees to 2-Port analyzer) or N5242A-419 (add extended power range and bias-tees to 4-Port analyzer) but deletes the bias tees from the test set.

The Option H85 does not increase the output power of the N5242A analyzer. This option only allows the N5242A analyzer to make high power measurements. The user must supply their own amplifier(s) and external components such as high power, couplers, attenuators and isolators to configure the analyzer for high power. These components are not supplied, or included with the Option H85. The user is responsible to ensure that these components meet their DUT requirements, and also protect the PNA from damage. Therefore, it is very important that you read this document thoroughly and follow the power level guide lines in [Table 1](#) through [Table 7](#) on [Page 15](#) through [Page 18](#).

---

**NOTE** The Bias Tee's are removed from the Option H85 to allow high power operation. Specifications for the Agilent N5242A Option H85, when configured in Standard Configuration, are the same as those of an N5242A PNA Series Network Analyzer with Options N5242A-219, 224, or N5242A-419, 423 with Option 080.

---

The instrument is shipped from the factory with jumper cables installed on the front panel in what is referred to as the “Standard Configuration.” Refer to [Figure 5](#) and [Figure 6](#) on [page 7](#). This configuration will allow the instrument to operate as a standard N5242A PNA Series Network Analyzer with Options N5242A-219, 224, or N5242A-419, 423.

The Agilent N5242A Option H85 bundles Options N5242A-219, 224 and N5242AH85-285 for 2-Port analyzers. The Agilent N5242A Option H85 bundles Options N5242A-419, 423, and N5242AH85-485 for 4-Port analyzers. More options are available for the Agilent N5242A Option H85 at additional prices.



---

## N5242AH85 Basic Option Configuration

### 2-Port Default Configuration Includes the Following Options:

- N5242A-200 (2-Ports, single source)
- N5242A-219 (add extended power range and bias-tees to 2-Port analyzer)
- N5242A-224 (add internal second source, combiner and mechanical switches to 2-Port analyzer)
- N5242AH85-285 (add extended power range to 2-Port analyzer, no bias tees)
- N5242A-080 (frequency offset measurements)

### 4-Port Default Configuration Includes the Following Options:

- N5242A-400 (4-Ports, dual source)
- N5242A-419 (add extended power range and bias-tees to 4-Port analyzer)
- N5242A-423 (add internal combiner and mechanical switches to 4-Port analyzer)
- N5242AH85-485 (add extended power range to 4-Port analyzer, no bias tees)
- N5242A-080 (frequency offset measurements)

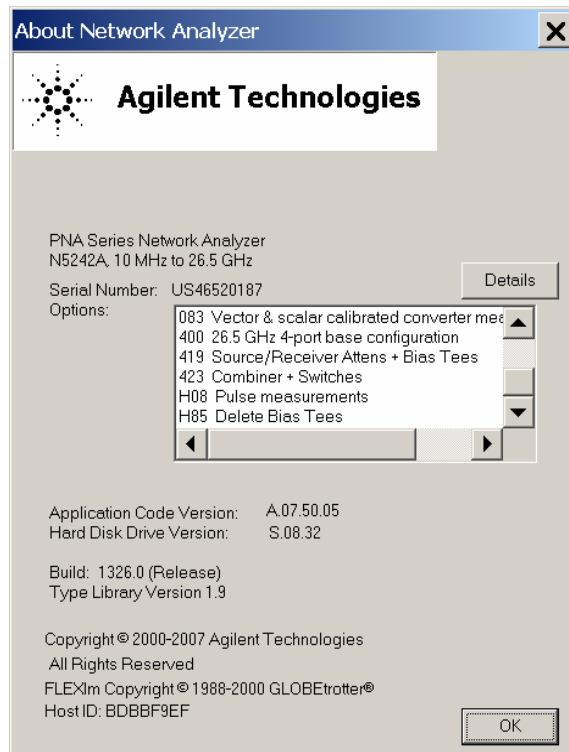

---

## Operation

The Agilent Option H85 can be configured differently for many applications. Included in this manual are five typical configurations:

- [Figure 7, “2-Port Two Way High Power Configuration.”](#)
- [Figure 8, “4-Port Four Way High Power Configuration.”](#)
- [Figure 9, “2-Port One Way High Power Configuration.”](#)
- [Figure 10, “4-Port One Way High Power Configuration.”](#)
- [Figure 11, “2-Port Forward DUT Configuration.”](#)

---

**NOTE** The internal firmware of the PNA has not been modified for this option. The power levels indicated on the Agilent N5242A Option H85 may differ depending on the user configuration that is chosen.

---

Refer to the configuration diagrams for external component connections and/or operating constraints when utilizing the high power capability of the Agilent N5242A Option H85. External components are not supplied with this option.

When using the Agilent N5242A Option H85 in the high power configuration (flow through R1 Loop), the analyzers R1 Input path must be set to External. In the **Trace/Chan** drop-down menu select **Channel > Hardware Setup > Path Config**. See [Figure 19 on page 27](#). In the application window, select **Port 1 Reference Mixer Switch > External** and press **OK** to active the R1 Input path. See [Figure 20 on page 28](#).

In this test set menu you can also select Internal, for normal operation (bypass R1 Loop). Refer to [Figure 20 on page 28](#).

---

**CAUTION** The maximum attenuator power setting for the receiver attenuator is 35 dB. The PNA Receiver Step Attenuators reduce the power to the A, B, C and D receivers. Power measurements to Test Ports 1, 2, 3 and 4 above +35 dBm will require additional attenuation. Add the appropriate amount of attenuation that will keep the coupler arm output power below the maximum receiver inputs. Refer to [Table 1 on page 15](#).

---

**CAUTION** Prior to powering-up the booster amplifier, it is highly recommended that the user verify the RF power levels seen by the various elements of the test setup. At high power levels an incorrect power level could permanently damage the instrument. Refer to [Table 1](#) through [Table 8](#) on [Page 15](#) through [Page 18](#).

---

Figure 1 N5242A Option H85 2-Port RF Standard Block Diagram

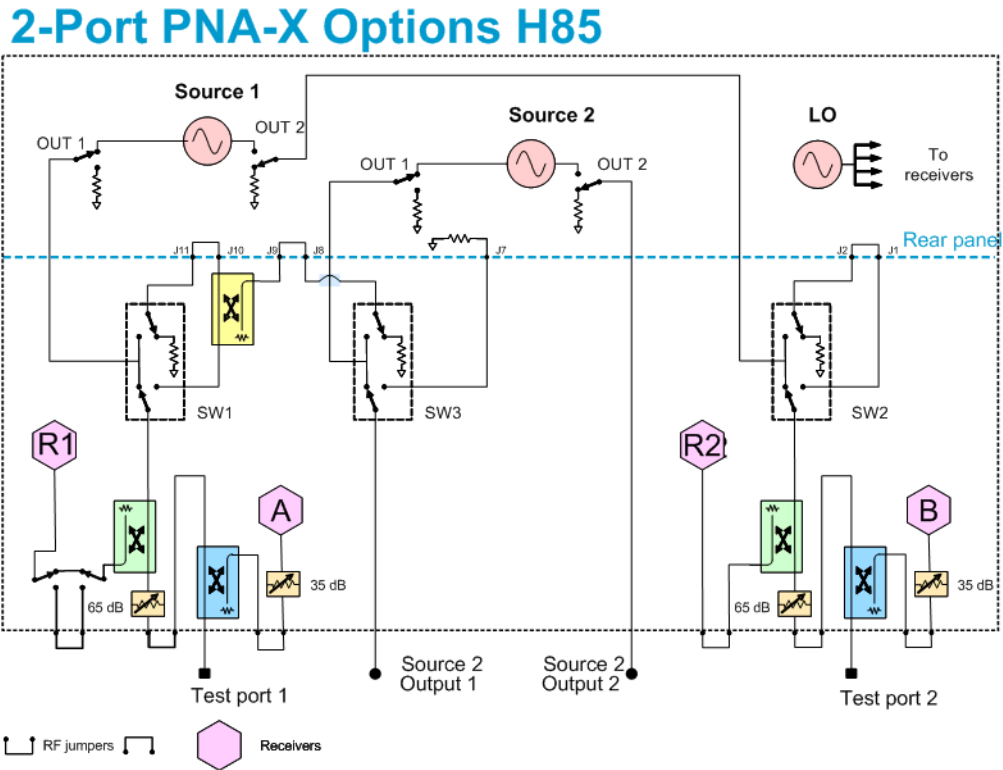

Figure 2 N5242A Option H85 4-Port RF Standard Block Diagram

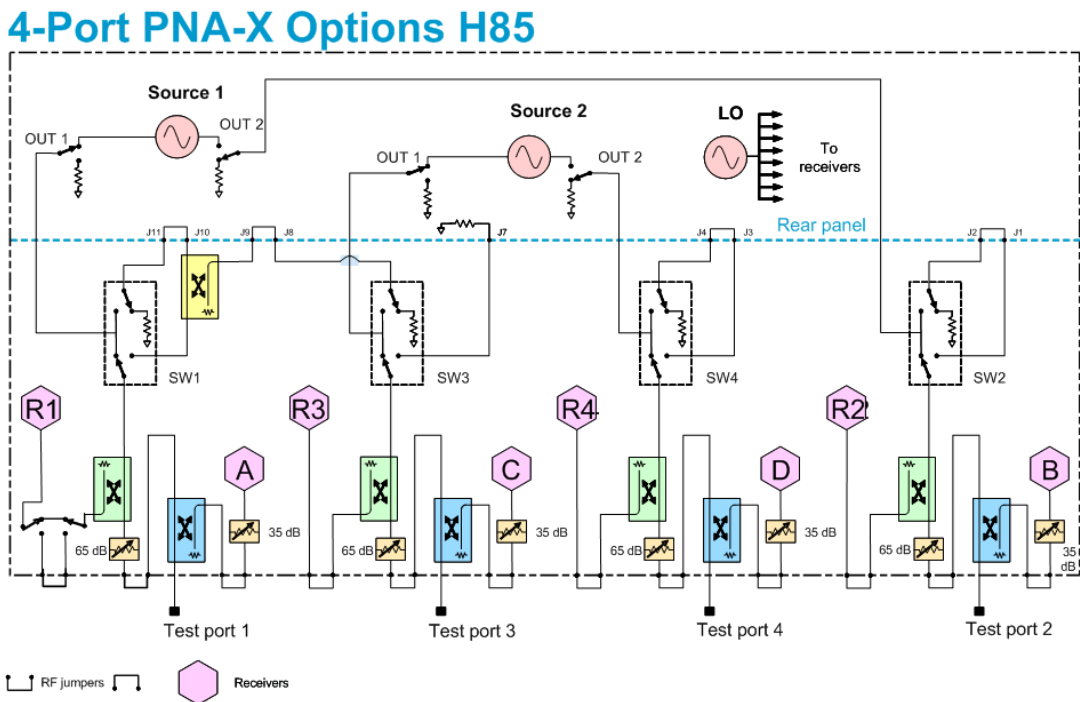

Figure 3 N5242A Option H85 2-Port with Option 029 Block Diagram

### 2-Port PNA-X Options H85 and 029

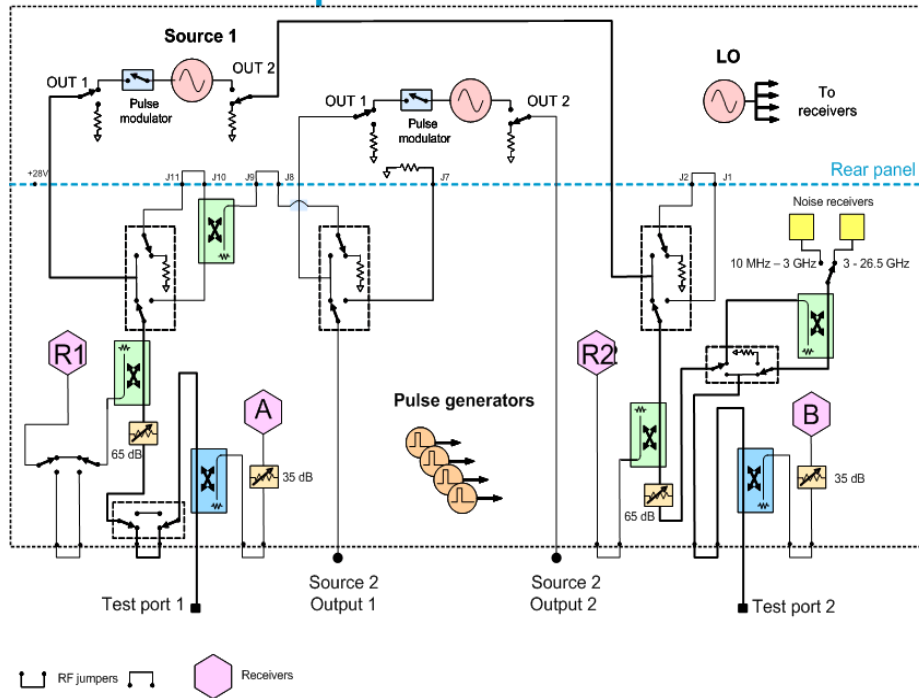

Figure 4 N5242A Option H85 4-Port with Option 029 Block Diagram

### 4-Port PNA-X Options H85 and 029

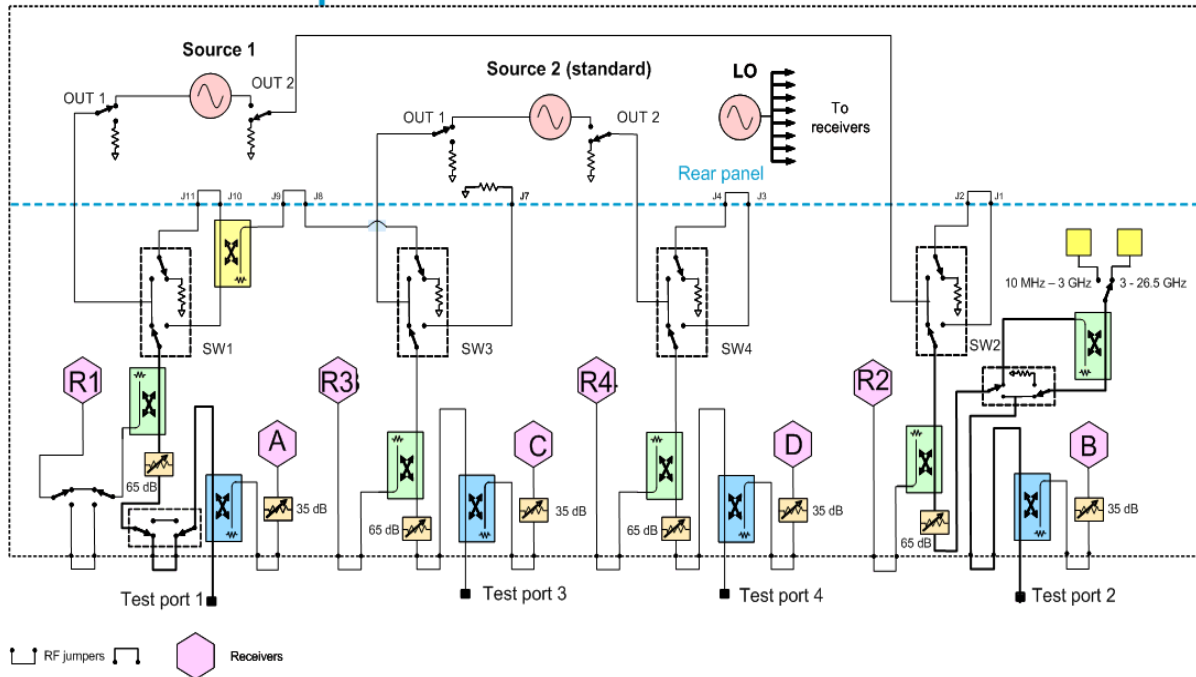

Figure 5 2-Port Front Panel

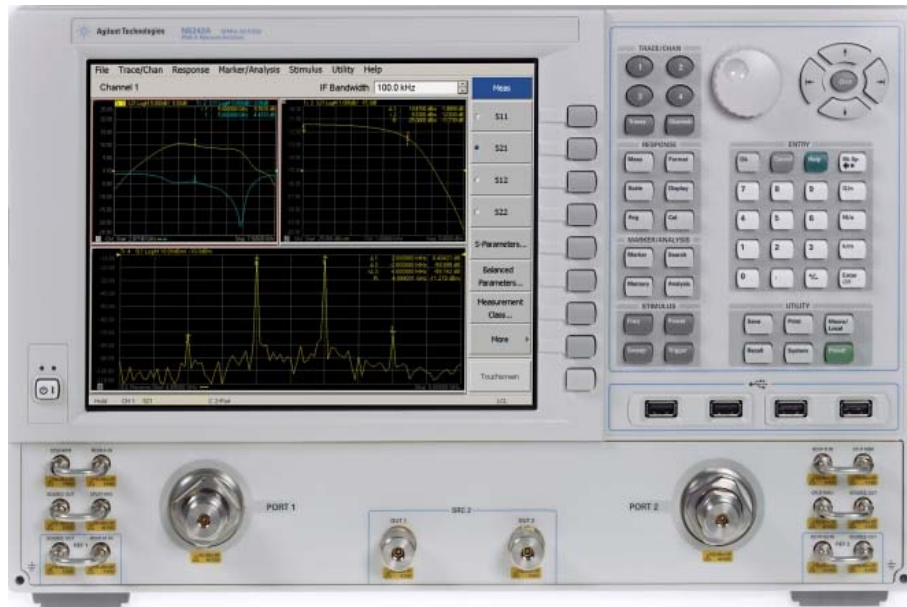
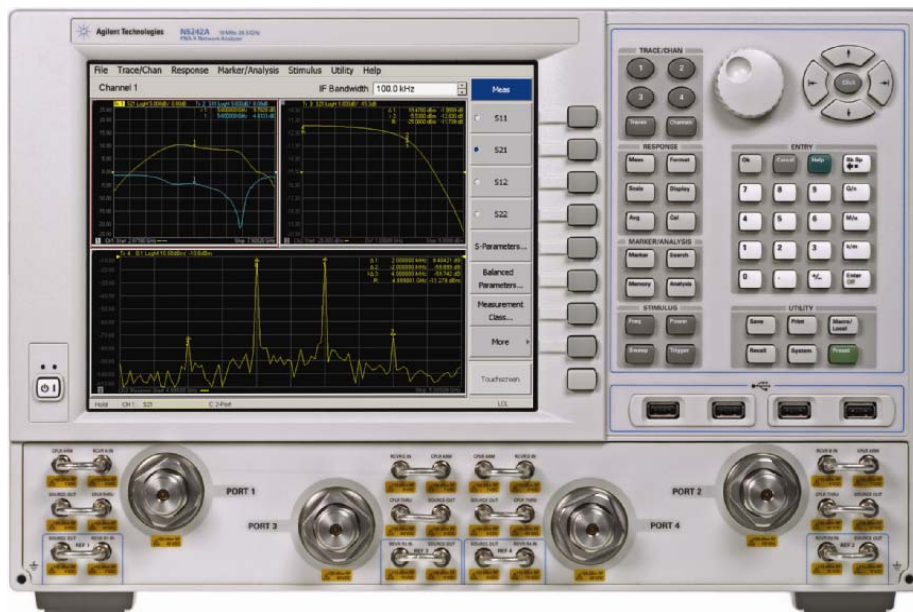

Figure 6 4-Port Front Panel



## Operation

[Figure 7, “2-Port Two Way High Power Configuration” on page 10](#). Ports 1 and 2 are configured to allow the user to stimulate each port with high power. Each port must have a high power amplifier and high power coupler. The isolators, reference and measured receiver attenuators are optional. They are dependent on the high power couplers coupling factor, amplifiers reverse isolation and power required to test the device. The attenuator, located at the high power coupler arm, may not be required if the coupling factor attenuates the signal adequately for the reference receiver channel. The same is also true for the measure receiver channels. The measure receiver attenuators for A IN and B IN may have sufficient range to compensate for the users desired power level. The isolators maybe eliminated if the amplifier reverse isolation is high.

[Figure 8, “4-Port Four Way High Power Configuration” on page 11](#). This configuration is similar to the 2-Port Two Way Configuration with the exception that Ports 1, 2, 3 and 4 are configured to allow the user to stimulate each port with high power. Each port must have a high power amplifier, high power coupler, isolator and attenuators. The isolators, reference and measured receiver attenuators are optional. They are dependent on the high power couplers coupling factor, amplifiers reverse isolation and power required to test the device. The attenuator, located at the high power coupler arm, may not be required if the coupling factor attenuates the signal adequately for the reference receiver channel. The same is also true for the measure receiver channels. The measure receiver attenuators for A IN, B IN, C IN and D IN may have sufficient range to compensate for the users desired power level. The isolators maybe eliminated if the amplifier reverse isolation is high. DUT is not shown in the figure.

[Figure 9, “2-Port One Way High Power Configuration” on page 12](#). This configuration allows the user to stimulate Port 1 with high power. Port 1 must have a high power amplifier, high power coupler, isolator and attenuators. The isolator, reference and measured receiver attenuators are optional. They are dependent on the high power couplers coupling factor, amplifiers reverse isolation and power required to test the device. The attenuator, located at the high power coupler arm, may not be required if the coupling factor attenuates the signal adequately for the reference receiver channel. The same is true for the measure receiver channels. The measure receiver attenuators for A IN and B IN may have sufficient range to compensate for the users desired power level. Port 2 has a high power isolator located between the SOURCE OUT and CPLR THRU. This isolator is required to protect the components inside the PNA. The isolator can be replaced by a high power attenuator or circulator.

[Figure 10, “4-Port One Way High Power Configuration” on page 13](#). This configuration allows the user to stimulate Port 1 with high power. Port 1 must have a high power amplifier, high power coupler, isolator and attenuators. The isolator, reference and measured receiver attenuators are optional. They are dependent on the high power couplers coupling factor, amplifiers reverse isolation and power required to test the device. The attenuator, located at the high power coupler arm, may not be required if the coupling factor attenuates the signal adequately for the reference receiver channel. The same is also true for the measure receiver channels. The measure receiver attenuators for A IN, B IN, C IN and D IN may have sufficient range to compensate for the users desired power level. Ports 2, 3 and 4 each have a high power isolator located between the SOURCE OUT and CPLR THRU. This isolator is required to protect the components inside the PNA. The isolator can be replaced by a high power attenuator or circulator.

Figure 11, “2-Port Forward DUT Configuration” on page 14. In this configuration the DUT supplies the power. The measure receiver attenuator for B IN may have sufficient range to compensate for the users desired power level. Port 2 has a high power isolator located between the SOURCE OUT and CPLR THRU. This isolator is required to protect the components inside the PNA. The isolator can be replaced by a high power attenuator or circulator. Reference Channel R1 can be set to internal.

---

**CAUTION** To reduce risk of damaging the PNA or your device, reduce the power and set the initial power setting to  $-65$  dBm at the test port.

The microwave PNA has 36 frequency bands. The firmware turns off the RF power level during band-crossings. If you are testing a high-gain device with an ALC when the PNA switches bands, the power shuts down and the DUT ALC attempts to increase the gain. Microseconds later the PNA power returns. However, in the short time frame the DUT or the VNA may be damaged. The Band Crossings are listed in [Table 9 on page 19](#).

---

**NOTE** For all high power configurations see the following maximum input levels. Refer to [Table 1](#) through [Table 8](#) on [Page 15](#) through [Page 18](#).

---

**Figure 7 2-Port Two Way High Power Configuration**

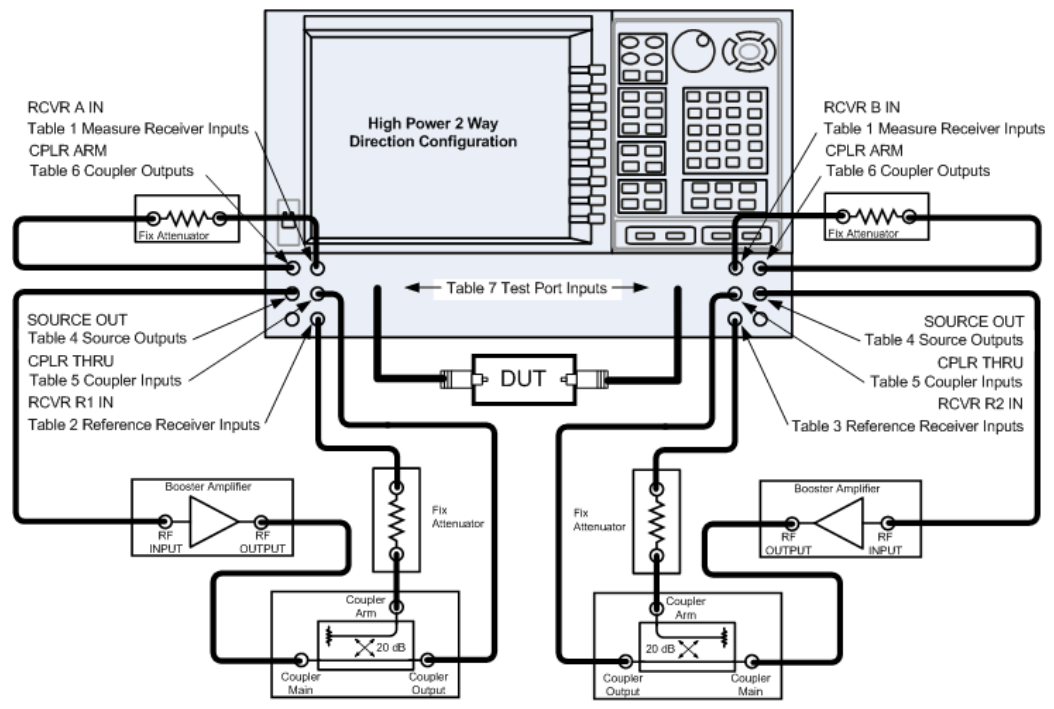
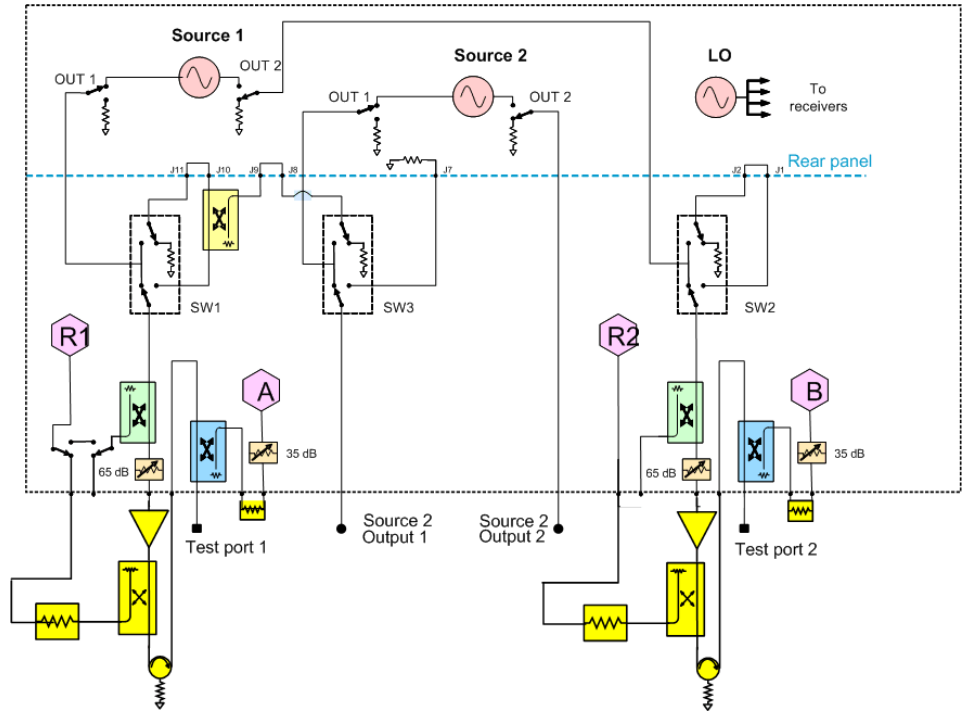
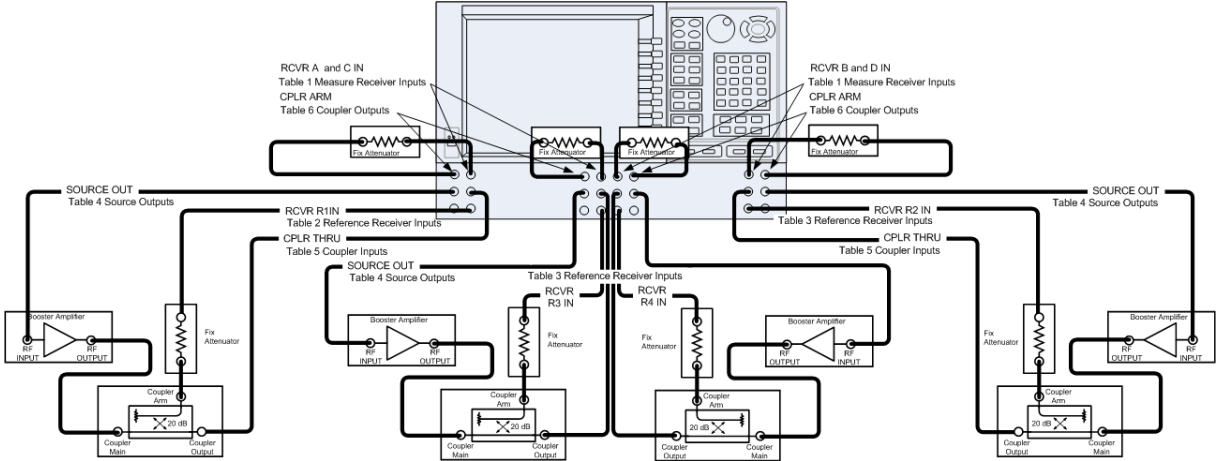
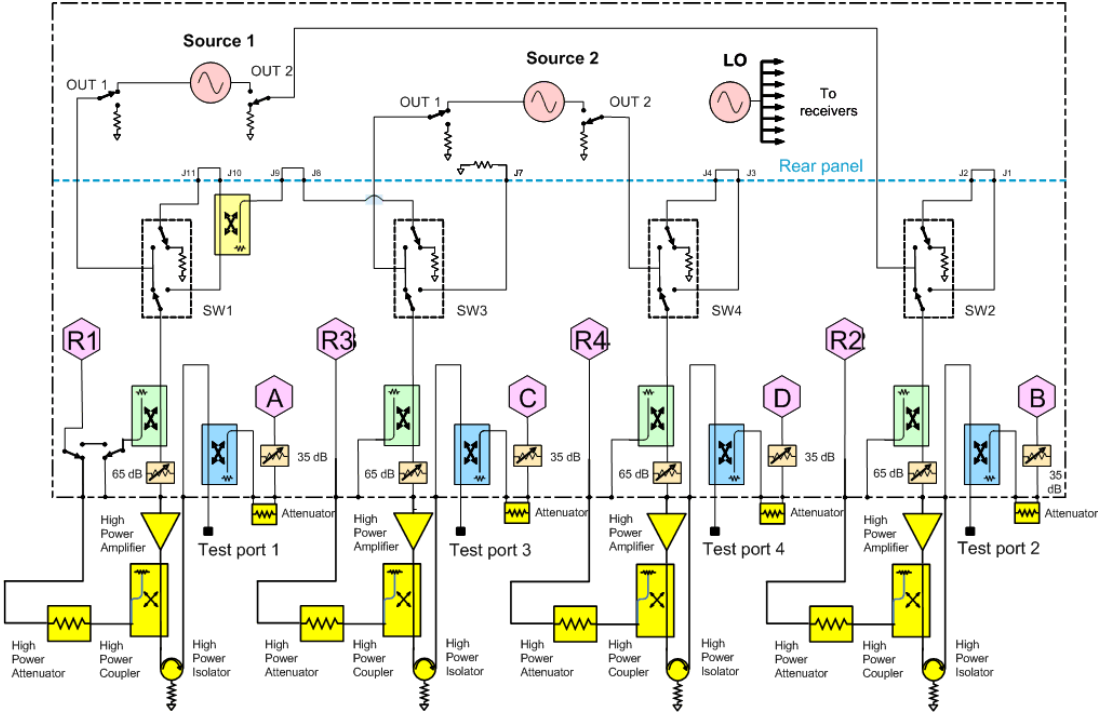



Figure 8 4-Port Four Way High Power Configuration



**Figure 9 2-Port One Way High Power Configuration**

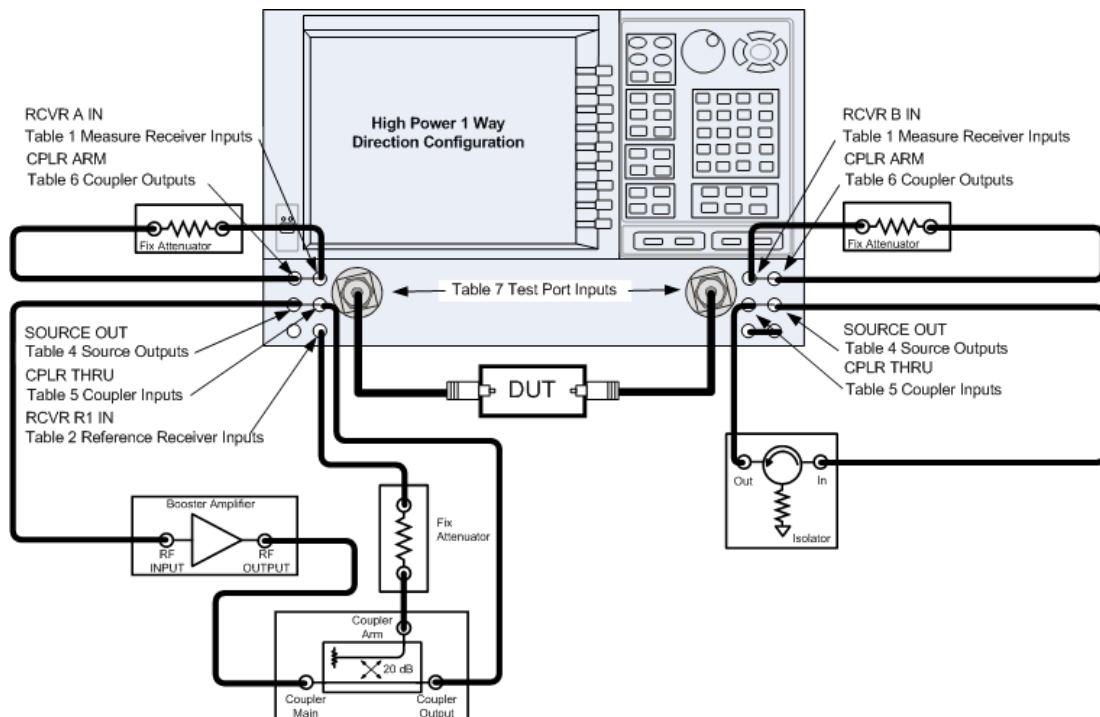
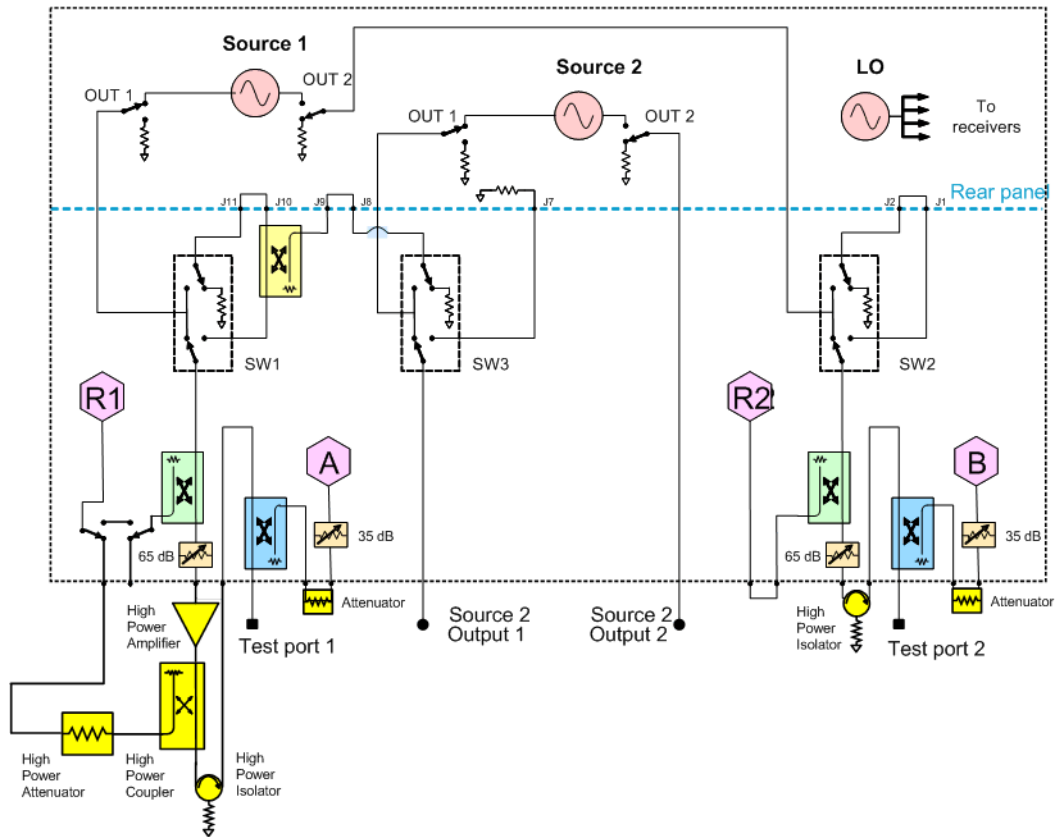
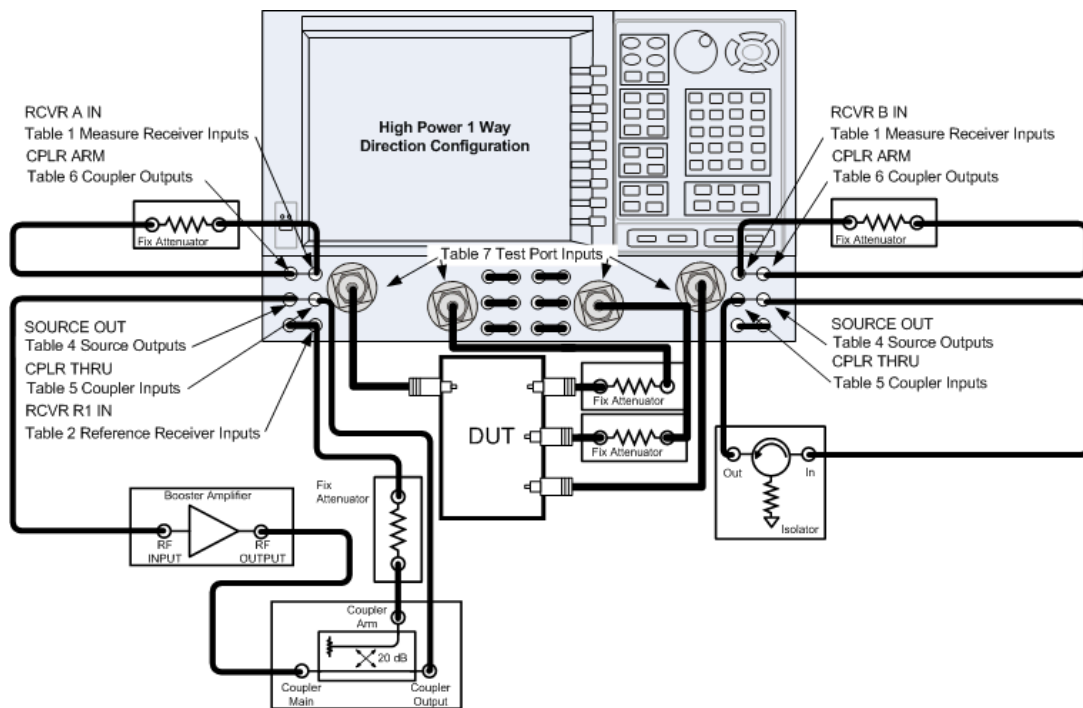
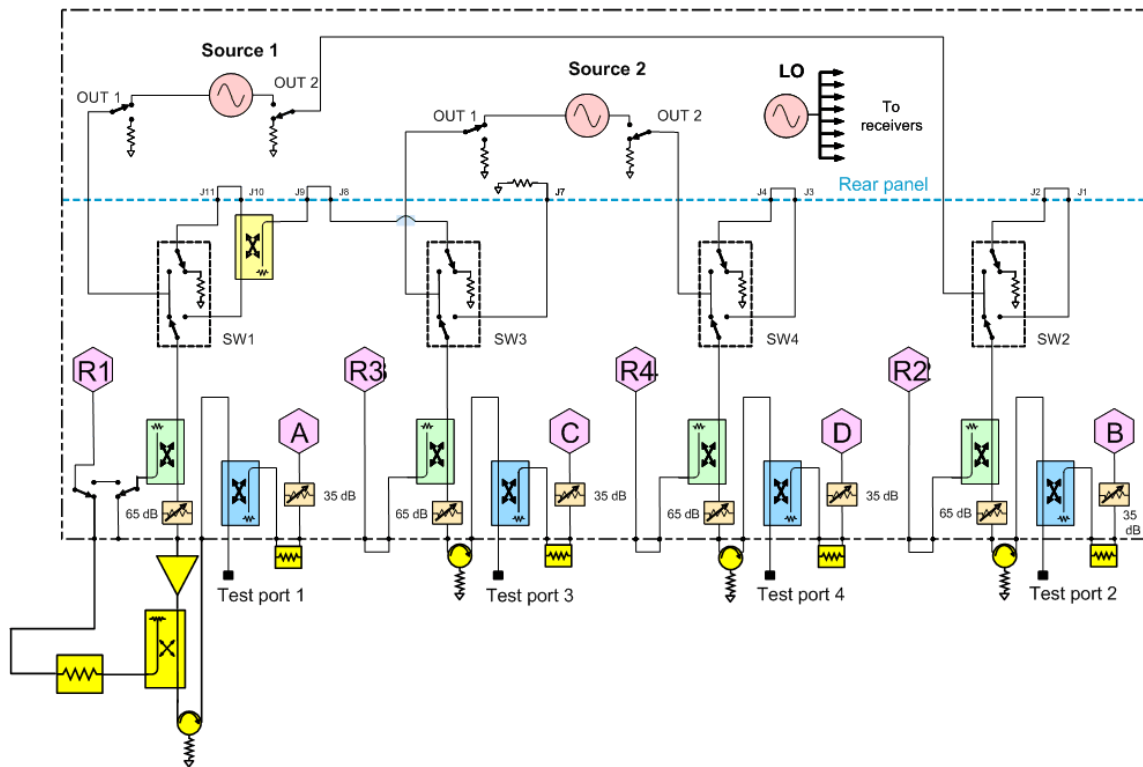
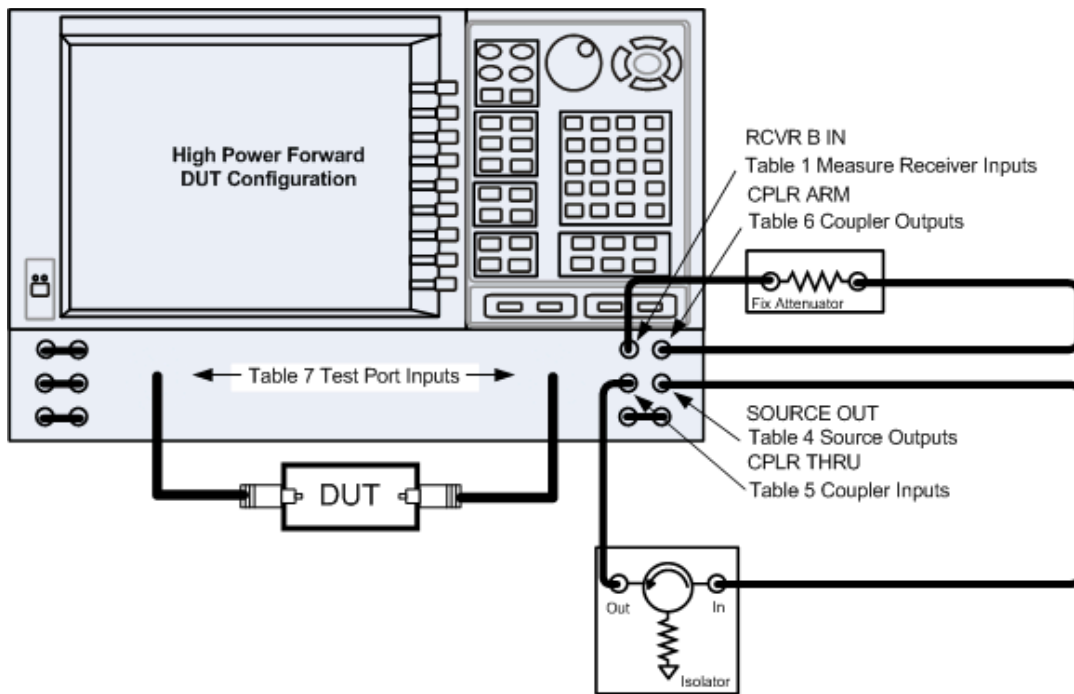
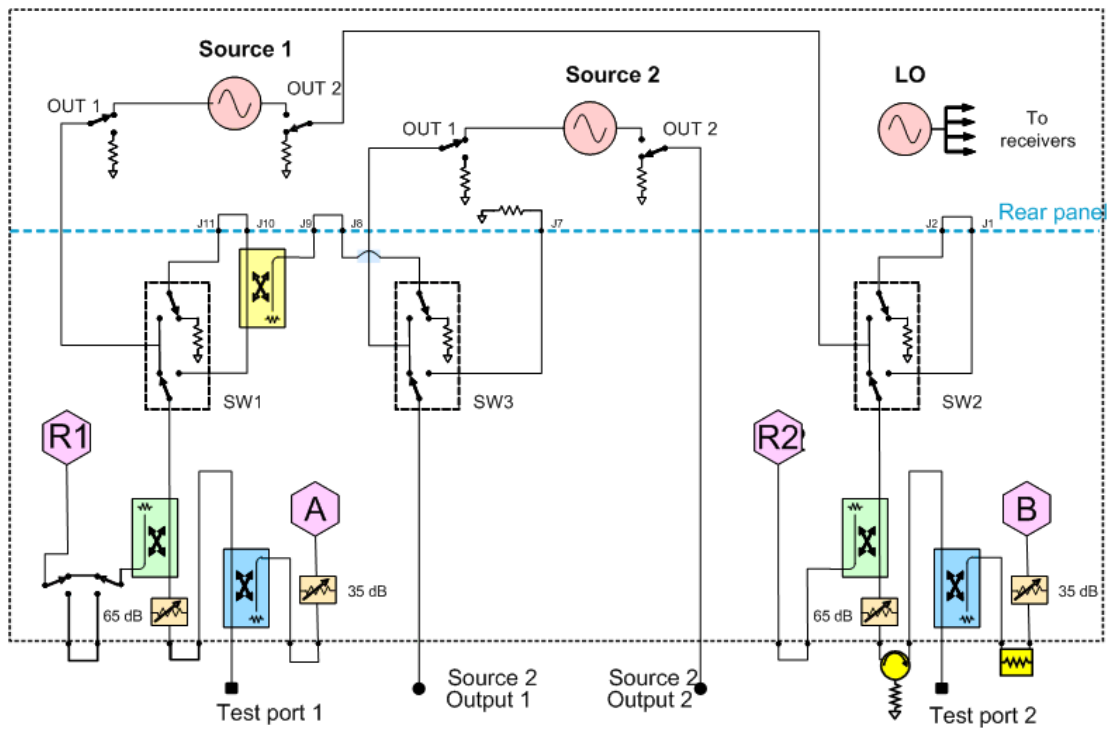

Figure 10 4-Port One Way High Power Configuration



**Figure 11 2-Port Forward DUT Configuration**



---

## Maximum Power Levels

---

**CAUTION** It is recommend that you do not operate components near damage or maximum levels. The power levels should be kept at less than 3 dB, preferably 6 dB, below damage and maximum levels.

---

**NOTE** Refer to your PNA specifications to optimize the power levels in the receivers.

---

**Table 1 Measurement Receiver Inputs**

Description	Typical
RCVR A IN through RCVR D IN @ 0.1 dB Typical Compression	
Maximum Input Level	All Options
10 MHz to 50 MHz	–
50 MHz to 500 MHz	–
500 MHz to 3.2 GHz	–2 dBm
3.2 GHz to 10 GHz	–2 dBm
10 GHz to 16 GHz	–2 dBm
16 GHz to 20 GHz	–2.5 dBm
20 GHz to 24 GHz	–4 dBm
24 GHz to 26.5 GHz	–4 dBm
Damage Level	
N5242AH85	+15 dBm
Maximum DC Level	
N5242AH85	0 V

**Table 2 R1 Reference Receiver Inputs**

<b>Description</b>	<b>Typical</b>
RCVR R1 IN @ Max Specified Output Power	
Maximum Input Level	All Options
10 MHz to 50 MHz	-6 dBm
50 MHz to 500 MHz	-5 dBm
500 MHz to 3.2 GHz	-5 dBm
3.2 GHz to 10 GHz	-2 dBm
10 GHz to 16 GHz	-3 dBm
16 GHz to 20 GHz	-6 dBm
20 GHz to 24 GHz	-9 dBm
24 GHz to 26.5 GHz	-18 dBm
Damage Level	
N5242AH85	+15 dBm
Maximum DC Level	
N5242AH85	±7 V

**Table 3 R2 - R4 Reference Receiver Inputs**

<b>Description</b>	<b>Typical</b>
RCVR R2 IN through RCVR R4 IN @ Max Specified Output Power	
Maximum Input Level	All Options
10 MHz to 50 MHz	-1 dBm
50 MHz to 500 MHz	-1 dBm
500 MHz to 3.2 GHz	-1 dBm
3.2 GHz to 10 GHz	0 dBm
10 GHz to 16 GHz	+1 dBm
16 GHz to 20 GHz	-3 dBm
20 GHz to 24 GHz	-4 dBm
24 GHz to 26.5 GHz	-13 dBm
Damage Level	
N5242AH85	+15 dBm
Maximum DC Level	
N5242AH85	± 15 V

**Table 4 Source Outputs**

<b>Description</b>	<b>Typical</b>
Port 1 Source Out through Port 4 @ Max Specified Output Power	
Maximum Input Level	All Options
10 MHz to 50 MHz	13 dBm
50 MHz to 500 MHz	13 dBm
500 MHz to 3.2 GHz	11 dBm
3.2 GHz to 10 GHz	14 dBm
10 GHz to 16 GHz	13 dBm
16 GHz to 20 GHz	10 dBm
20 GHz to 24 GHz	9 dBm
24 GHz to 26.5 GHz	2 dBm
Damage Level	
N5242AH85	+30 dBm
Maximum DC Level	
N5242AH85	± 0V

**Table 5 Coupler Inputs**

<b>Description</b>	<b>Typic.</b>
Port 1 CPLR THRU through Port 4 @ Insertion Loss of Coupler Thru	
Maximum Input Level	All Options
10 MHz to 50 MHz	0 dBm
50 MHz to 500 MHz	-0.75 dBm
500 MHz to 3.2 GHz	+1.0 dBm
3.2 GHz to 10 GHz	-1.25 dBm
10 GHz to 16 GHz	-1.75 dBm
16 GHz to 20 GHz	-2.25 dBm
20 GHz to 24 GHz	-2.5 dBm
24 GHz to 26.5 GHz	-2.5 dBm
Damage Level	
N5242AH85	+43 dBm
Maximum DC Level	
N5242AH85	0 V

**Table 6 Coupler Outputs**

<b>Description</b>	<b>Typical</b>
Port 1 CPLR ARM through Port 4 @ Max Specified Output Power	
Damage Input Level	
N5242AH85	+30 dBm
Maximum DC Level	
N5242AH85	± 7 V

**Table 7 Test Port Input**

<b>Description</b>	<b>Typical</b>
Test Port 1 through Port 4 @ Max Specified Output Power	
Damage Input Level	
N5242AH85	+43 dBm
Maximum DC Level	
N5242AH85	± 0 V

**Table 8 Watts to dBm Reference Table**

<b>Linear (watts)</b>	<b>Log (dBm)</b>
0.001	+0
0.01	+10
0.1	+20
1	+30
2	+33
4	+36
10	+40
20	+43
40	+46
50	+47
100	+50
200	+53



**Table 9 Frequency Band-Crossings**

Band	Mixer Brick L.O. Harmonic Number (N)	①	②	③	④
		A11 Synthesizer Frequency (GHz)	A21 MA 26.5 Frequency (GHz)	A4/A7 Synthesizer Frequency (GHz)	A5/A8 Source Frequency (GHz)
0	-	-	-	-	-
1	-	-	-	-	-
2	1	0.012535 to 0.016535	0.012535 to 0.016535	0.010 to 0.014	0.010 to 0.014
3	1	0.016535 to 0.021535	0.016535 to 0.021535	0.014 to 0.019	0.014 to 0.019
4	1	0.021535 to 0.029535	0.021535 to 0.029535	0.019 to 0.027	0.019 to 0.027
5	1	0.029535 to 0.040535	0.029535 to 0.040535	0.027 to 0.038	0.027 to 0.038
6	1	0.040535 to 0.055535	0.040535 to 0.055535	0.038 to 0.053	0.038 to 0.053
7	1	0.060606 to 0.082606	0.060606 to 0.082606	0.053 to 0.075	0.053 to 0.075
8	1	0.082606 to 0.112606	0.082606 to 0.112606	0.075 to 0.105	0.075 to 0.105
9	1	0.112606 to 0.153606	0.112606 to 0.153606	0.105 to 0.146	0.105 to 0.146
10	1	0.153606 to 0.212606	0.153606 to 0.212606	0.146 to 0.205	0.146 to 0.205
11	1	0.212606 to 0.257606	0.212606 to 0.257606	0.205 to 0.250	0.205 to 0.250
12	1	0.257606 to 0.403606	0.257606 to 0.403606	0.250 to 0.396	0.250 to 0.396
13	1	0.403606 to 0.507606	0.403606 to 0.507606	0.396 to 0.500	0.396 to 0.500
14	1	0.507606 to 0.635606	0.507606 to 0.635606	0.500 to 0.628	0.500 to 0.628
15	1	0.635606 to 1.007606	0.635606 to 1.007606	0.628 to 1.000	0.628 to 1.000
16	1	1.007606 to 1.507606	1.007606 to 1.507606	1.000 to 1.500	1.000 to 1.500
17	1	1.507606 to 2.007606	1.507606 to 2.007606	1.500 to 2.000	1.500 to 2.000
18	1	2.007606 to 3.007606	2.007606 to 3.007606	2.000 to 3.000	2.000 to 3.000
19	1	3.007606 to 3.207606	3.007606 to 3.207606	3.000 to 3.200	3.000 to 3.200
20	1	3.207606 to 4.007606	3.207606 to 4.007606	3.200 to 4.000	3.200 to 4.000
21	1	4.007606 to 5.339606	4.007606 to 5.339606	4.000 to 5.332	4.000 to 5.332
22	1	5.339606 to 6.759606	5.339606 to 6.759606	5.332 to 6.752	5.332 to 6.752
23	1	6.759606 to 8.007606	6.759606 to 8.007606	6.752 to 8.000	6.752 to 8.000
24	1	8.007606 to 8.507606	8.007606 to 8.507606	8.000 to 8.500	8.000 to 8.500
25	1	8.507606 to 10.67161	8.507606 to 10.67161	8.500 to 10.664	8.500 to 10.664
26	1	10.67161 to 12.00761	10.67161 to 12.00761	10.664 to 12.000	10.664 to 12.000
27	1	12.00761 to 12.80761	12.00761 to 12.80761	12.000 to 12.800	12.000 to 12.800
28	1	12.80761 to 13.51761	12.80761 to 13.51761	12.800 to 13.510	12.800 to 13.510
29	1	6.758803 to 7.703803	13.51761 to 15.40761	6.755 to 7.700	13.510 to 15.400
30	1	7.703803 to 8.003803	15.40761 to 16.00761	7.700 to 8.000	15.400 to 16.000
31	1	8.003803 to 9.003803	16.00761 to 18.00761	8.000 to 9.000	16.000 to 18.000
32	1	9.003803 to 10.00381	18.00761 to 20.00761	9.000 to 10.000	18.000 to 20.000
33	1	10.00381 to 10.66781	20.00761 to 21.33561	10.000 to 10.664	20.000 to 21.328
34	1	10.66781 to 11.25381	21.33561 to 22.50761	10.664 to 11.250	21.328 to 22.500
35	1	11.25381 to 12.00381	22.50761 to 24.00761	11.250 to 12.000	22.500 to 24.000
36	1	12.00381 to 13.25381	24.00761 to 26.50761	12.000 to 13.250	24.000 to 26.500

## Making High Power Measurements With Option H85

This section describes how to set up the analyzer to perform high power measurements. Analyzers equipped with the Option H85 can be configured to measure high power devices. This ability is useful if the required power for the device under test is greater than the analyzer can provide, or if the maximum output power from an amplifier under test exceeds safe input limits for a standard analyzer.

This 2-Port example of the high power procedure chooses an optimal power level of  $-12$  dBm for all receivers. You may choose to optimize your measurement performance by using [Table 1](#) through [Table 7](#) on [Page 15](#) through [Page 18](#).

### Typeface Key Conventions

The following key conventions are used throughout this document.

- **[HARDKEYS]** are labeled front panel keys.
- **SOFTKEYS** are unlabeled key whose function is indicated on the instrument display.

## Initial Setup

1. If the analyzer is in the standard mode configuration remove the jumper between Port 1 SOURCE OUT and CPLR THRU connector on the front panel. This can also be done for Port 2 if high power measurements are necessary for the reverse parameters of a device under test (DUT). Two booster amplifiers and two 20 dB couplers are required for both forward and reverse measurements. Refer to [Figure 12](#).
2. Connect the booster amplifier RF INPUT connector to the Port 1 SOURCE OUT connector on the front panel of the analyzer.
3. Connect a 20 dB coupler (that operates within the frequency range of interest) to the booster amplifier RF OUTPUT connector.

**Figure 12** Booster Amplifier and 20 dB Coupler Connection Setup

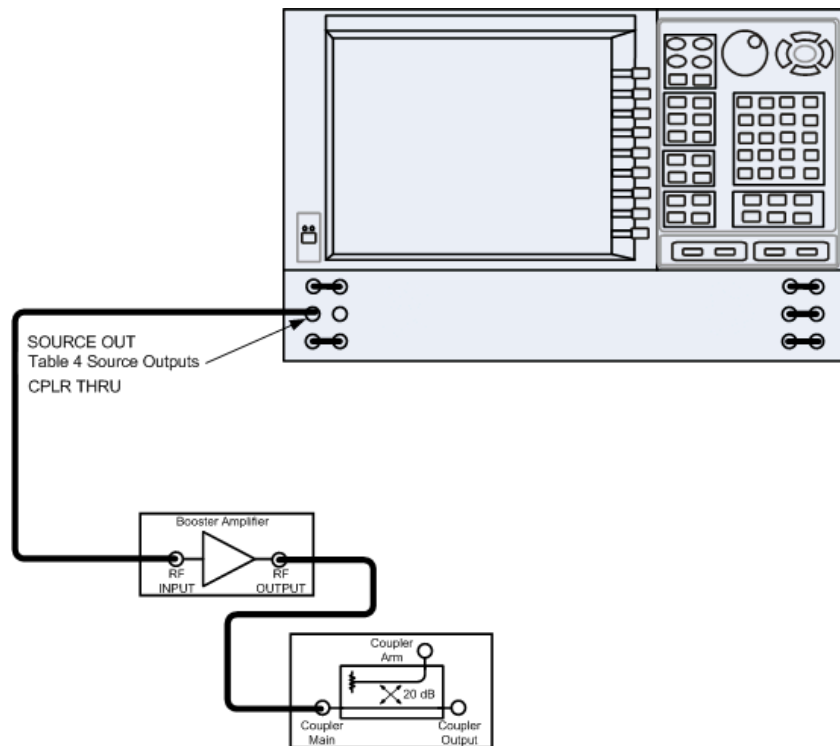

## Determining Power Levels

Before continuing, save this state and set it up as the **User Preset**. The User Preset Conditions can be found in the PNA Series Network Analyzer's help menu.

1. Press **[Help]** on the front panel. In the **Help** drop-down menu select **Network Analyzer Help**. Type **User Preset**, in the index or search field. This will describe how to setup a User Preset. The final state should be saved as the User Preset to avoid an over power condition from the factory preset.

**Figure 13 Help Menu**

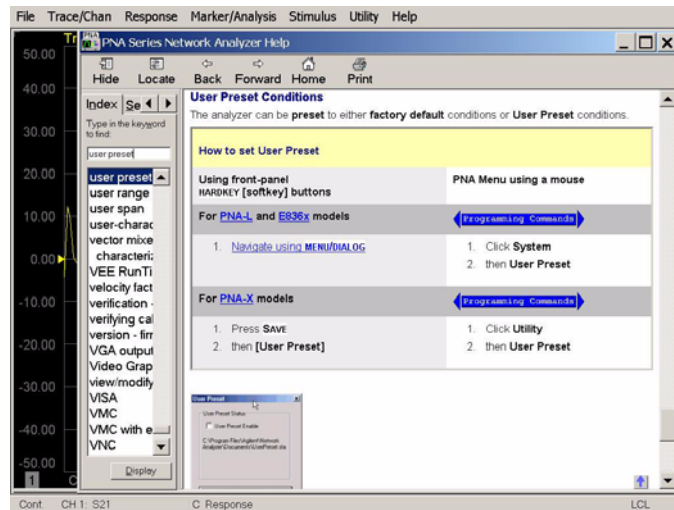

To find the User Preset:

2. In the **Utility** drop-down menu select **User Preset**. Check **User Preset Enable > Save current state as User Preset** and press **OK**. See [Figure 14](#).

**Figure 14 User Preset**

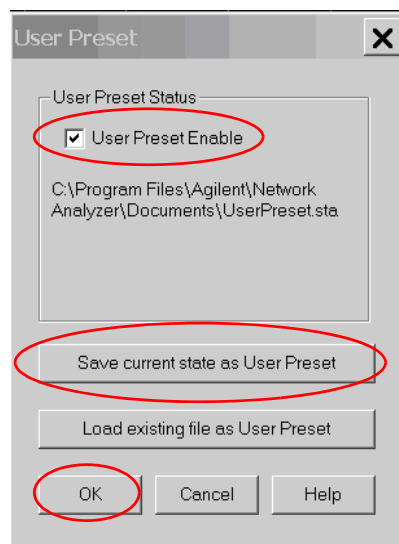

- In the **Stimulus** drop-down menu select **Power > Power and Attenuators**. In the application window type **[-20 dBm]** into **Port Power** for **Port 1**. Verify that **Port Powers Coupled** is checked to ensure that Ports 1 and Port 2 power levels are the same. Press **OK**. Uncoupled ports should be used when adjusting the S12 power level. See [Figure 15](#).

**Figure 15 Power and Attenuators**

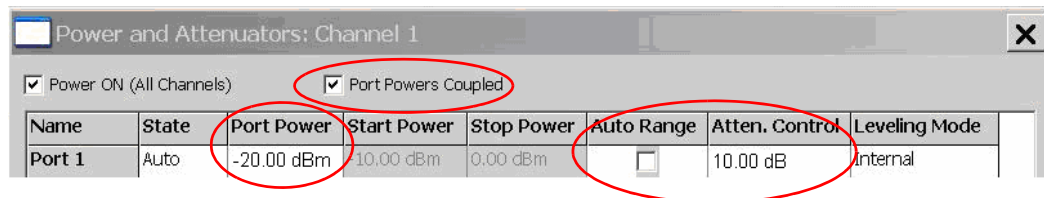

- Turn On the booster amplifier.
- Measure the output power from the coupled arm and the open port “Coupler Output” of the coupler, using a power meter and sensor.

---

**NOTE** Depending on the power used, additional attenuation may have to be added between the coupler and the power meter.

---

- Verify the gain of the booster amplifier(s). For example; if the analyzer output power level was set to  $-20$  dBm and the output power measured from the open end of the coupler was  $-5$  dBm, the gain of the booster amplifier would be  $+15$  dB.
- Verify that the power measured in the previous steps is within the acceptable limits (less than  $-12$  dBm for the coupled arm, less than  $+43$  dBm for the open port). Estimate the maximum power level needed to force the DUT into compression.
- At the maximum estimated power level, determine if the maximum output power from the coupled arm of the coupler will be higher than the acceptable limit. If so, add the appropriate amount of attenuation that will keep the coupler arm output power below  $-12$  dBm.

## Additional Setup

9. Turn Off the booster amplifier.
10. Connect the open port of the 20 dB coupler to the Port 1 CPLR THRU connector on the front panel. This can also be done on Port 2 if reverse parameters high power measurements are required.
11. Disconnect the REFERENCE SOURCE OUT and RCVR R1 IN jumper on the front panel. Connect the coupled arm of the 20 dB coupler (along with any added attenuation) to the RCVR R1 IN. The same instructions apply to Port 2 with one exception; disconnect the jumper to RCVR R2 IN if high power measurements are required for the reverse parameters.

**Figure 16 PNA Port 1 Amplifier, Coupler, Attenuator Connections**

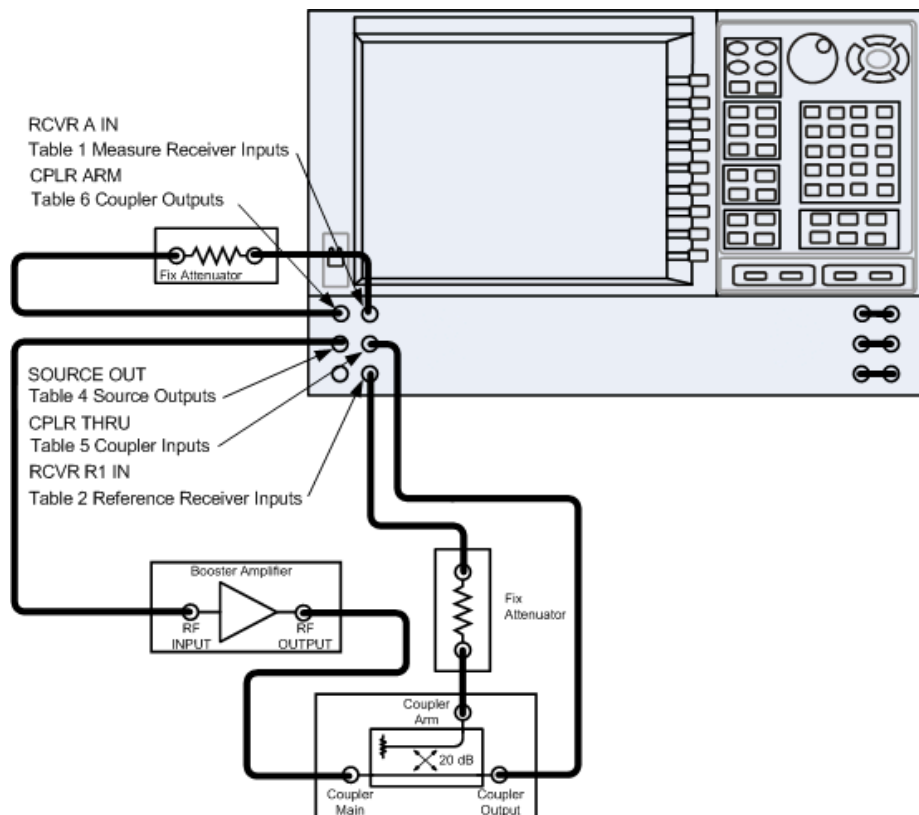

## Selecting Power Ranges and Attenuator Settings

12. Select a power range that will not exceed the maximum estimated power level, but will force the DUT into compression. For example; if your booster amplifier has a gain of +15 dB, the DUT will compress if supplied with +15 dBm. You may need to adjust the analyzer output power to not exceed 0 dBm.

To adjust the output power follow steps a and b.

- a. In the **Stimulus** drop-down menu select **Power > Power and Attenuators**.
  - b. In the application window, clear the **Auto Range** box and type **[10 dB]** into **Atten. Control for Port 1**. Verify that **Port Powers Coupled** is checked to ensure that Ports 1 and Port 2 power levels are the same. Press **OK**. Refer to [Figure 15 on page 23](#).
13. Estimate the maximum amount of gain that could be provided by the DUT, and as a result, the maximum amount of power that could be received by Test Port 2 when the DUT is in compression. For example; if a DUT with a maximum gain of +10 dB receives an input of +10 dBm, the maximum amount of power that could be received by Test Port 2 is +20 dBm. An isolator or attenuator may be required depending on the amount of power at Test Port 2. For Port 2 isolators and attenuator connections, an isolator is placed between the CPLR THRU and SOURCE OUT as shown in [Figure 17 on page 25](#).

**Figure 17 Isolators and Attenuator Connections**

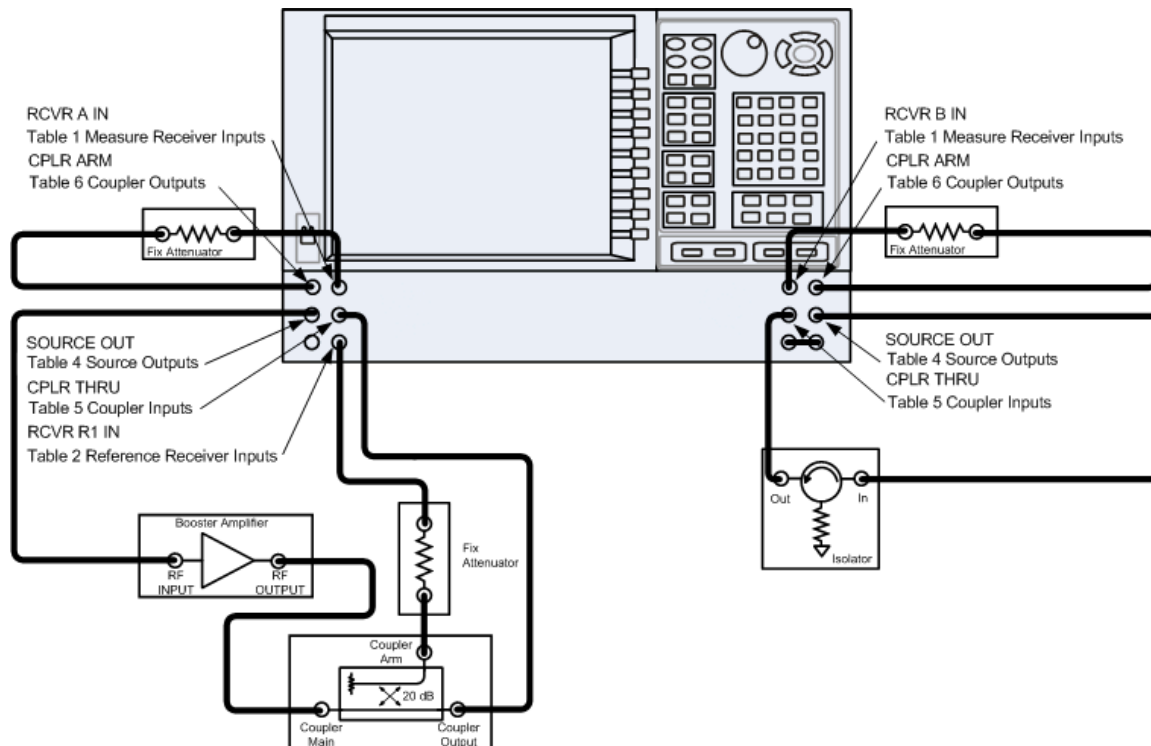

## Making High Power Measurements With Option H85

14. Calculate the amount of attenuation needed between the analyzer's coupler and receivers, so that you do not exceed the optimum receiver power level of  $-12$  dBm.

It will be necessary to take the following into consideration:

- Receiver A will be coupled to the analyzer RF path that could receive power reflections as high as  $+10$  dBm.
- Receiver B will be coupled to the analyzer RF path that could receive a maximum of  $+20$  dBm from the DUT.
- Analyzer coupler loss is  $-13$  dB.
- The optimum receiver power level is  $-12$  dBm.

With the previous points in mind, the amount of attenuation can be calculated from the following equations:

$$\text{Receiver Attenuator A} = +10\text{dBm} - 13\text{dBm} - (-12\text{dBm}) \quad \text{Attenuator A} = +10\text{dBm}$$

$$\text{Receiver Attenuator B} = +20\text{dBm} - 13\text{dBm} - (-12\text{dBm}) \quad \text{Attenuator B} = +20\text{dBm}$$

15. Set the receiver attenuator to the value calculated in the previous step (rounding off to the highest 5 dB step). Setting the receiver attenuation will establish the internal attenuation. In the **Stimulus** drop-down menu select **Power > Power and Attenuators**. In the application window, select **Receiver Attenuators**. Set Receiver A to **[10 dB]** and Receiver B to **[20 dB]**, see [Figure 18](#). Press **OK**. Power levels greater than  $+35$  dBm will require additional attenuation between Port 2 access ports CPLR ARM and RCVR B IN, see [Figure 17 on page 25](#).

**Figure 18** Receiver Attenuators





16. Turn On the booster amplifier.

**CAUTION** From this point forward, *do not* press Preset unless you have turned off the booster amplifier(s), or have renamed and saved this state as User Preset. Pressing Preset will return the analyzer to its default power level and default internal attenuator settings. This increase in power may result in damage to the DUT or analyzer.

17. In the **Trace/Chan** drop-down menu select **Channel > Hardware Setup > Path Config.**

**Figure 19** Trace/Chan

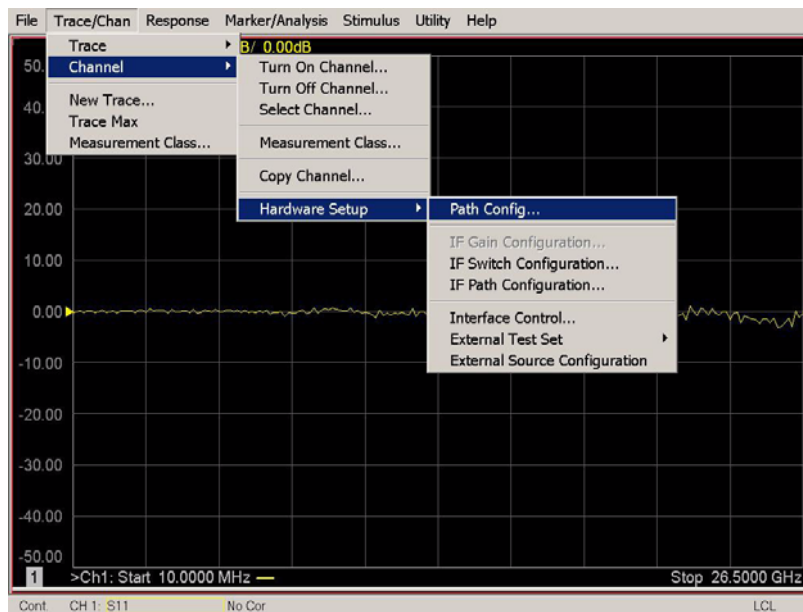

18. In the application window, select **Port 1 Reference Mixer Switch** > **External** and press **OK** to activate the R1 Input path.

**Figure 20** Port 1 Mixer Switch

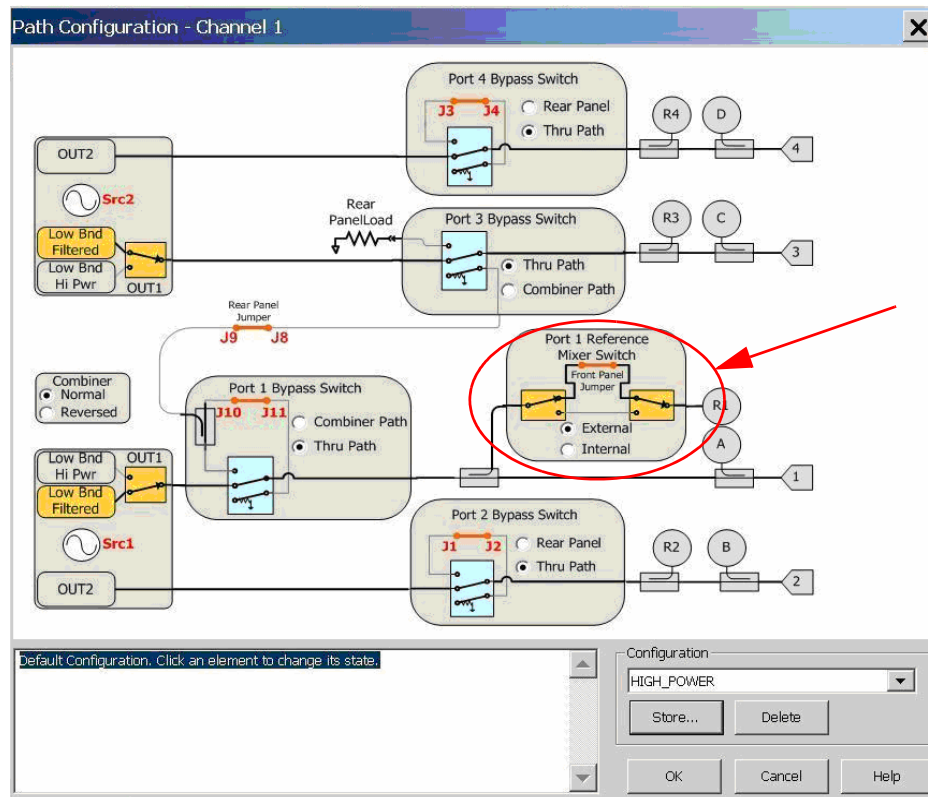

19. Measure the output power at Test Port 1, using a power meter. Verify the power measurement.

If you are measuring a highly reflective device, a high power isolators should be inserted between the 20 dB coupler and CPLR THRU front panel ports to protect Port 1 Source.

## Final Setup

20. Verify that all of the power and attenuator settings are correct.

21. In the **Response** drop-down menu select **Measure > S21**.

**Figure 21** Response Menu

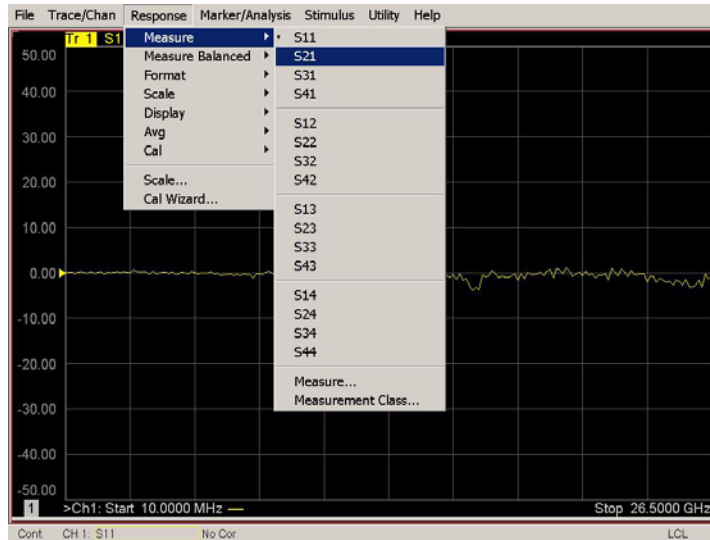

22. To Perform a response calibration following steps a, b, c and d:

- a. Connect the test port cables of the analyzer to form a thru configuration.
- b. In the **Response** drop-down menu select **Cal Wizard** (see [Figure 21](#)). In the application window, select **UNGUIDED Calibration (Response, 1-port 2-port): Use Mechanical Standards > Next**.

**Figure 22** Mechanical Standards

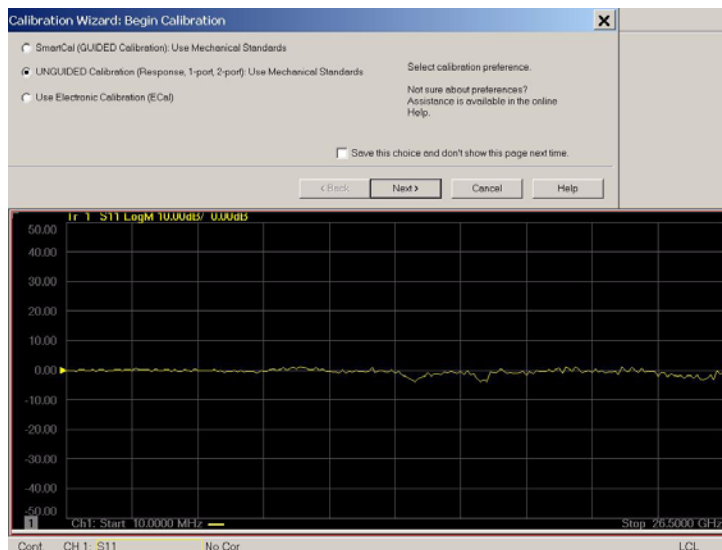

c. Select **Response** > **Next**.

**Figure 23**     **Response**

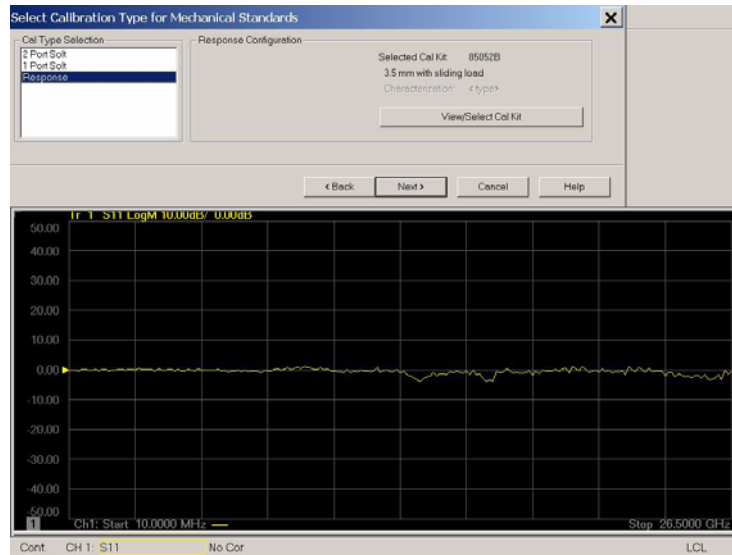

d. Select **THRU** > **Next**. Follow the analyzers window prompts to finish calibration.

**Figure 24**     **THRU**

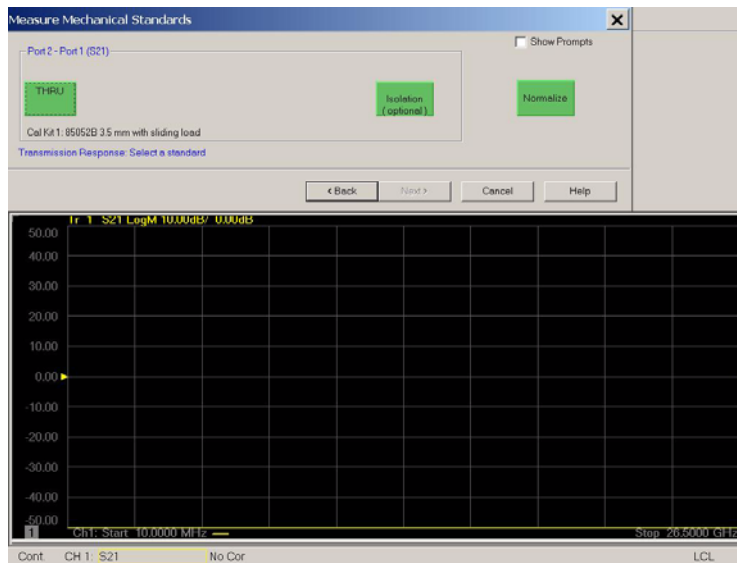

23. Configure the test setup as shown in [Figure 25](#). Turn On the DUT and measure the **S21** gain of the amplifier under test to confirm the proper operation of the measurement test setup.

**Figure 25 Forward High Power Measurement Configuration**

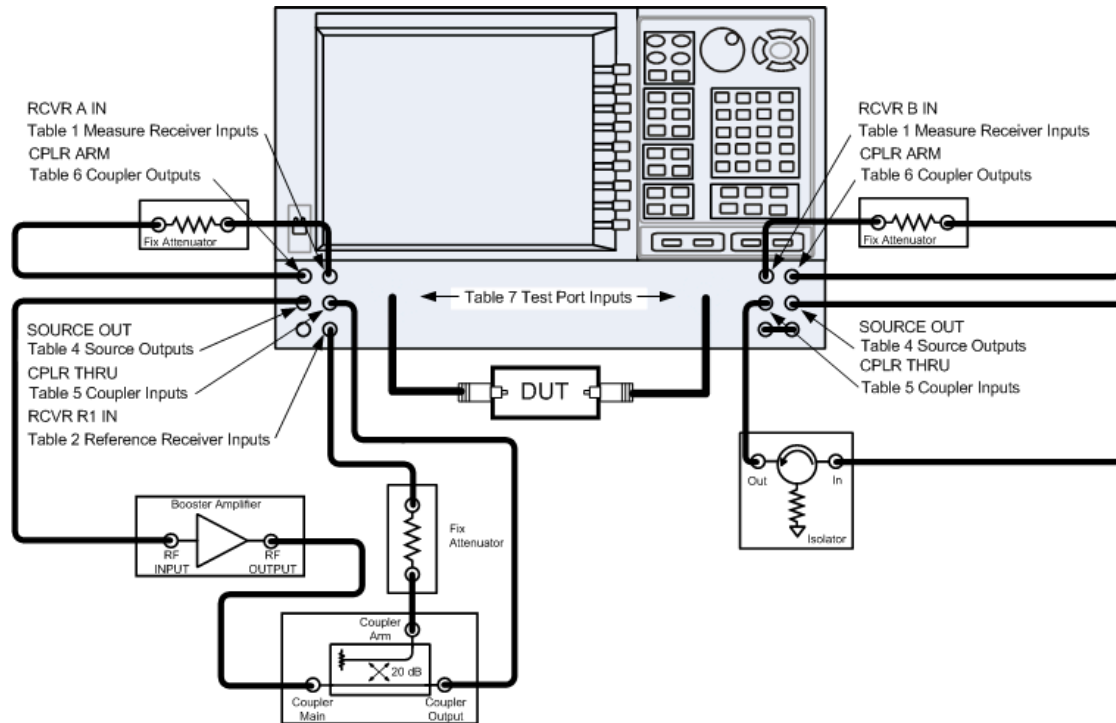

24. Continue with any other high power measurements.

---

**NOTE** Ratio measurements, such as gain, will be correctly displayed. However, the displayed absolute power levels on the analyzer will *not* be correct. To correctly interpret power levels and the gain of the booster amplifier, the attenuator setting must be taken into consideration.

---

If no calibration has been performed or if the instrument is in an un-calibrated state, the following must be taken into consideration when interpreting the measured data:

- The value of attenuation added to receiver A and B.
- The R channel reference level supplied from the coupler arm of the 20 dB coupler.

This procedure can be repeated to setup the reverse high power configuration.

## Specifications

Specifications for the N5242A Option H85 are the same as the standard N5242A Options 200/219/224 (2-Port PNA-X) or Options 400/419/423 (4-Port PNA-X) with Option 080. The Option H85 is a modified version of the Option N5242A-219 or N5242A-419. This modification eliminates the bias tees from the Port 1, Port 2, Port 3 and Port 4 Source paths. Refer to “[N5242AH85 Basic Option Configuration](#)” on page 3 for 2-Port or 4-Port options.

Specifications can be viewed or printed from the PNA Series Data Sheet (a condensed version of the specifications). Visit our web site at <http://www.agilent.com/find/pna>, select your analyzer model number (N5242A) in the search field and select the data sheet or manual of your choice.

The high power or large signal capability specifications for the Option H85 are not tested at the factory, in the field or at service centers.

---

## Service Information

Information can be found in the Agilent Technologies Data Sheet and Technical Specification N5242A 2-Port & 4-Port PNA-X Network Analyzers. Agilent part number N5242-90007. This document can be found using the our web site at <http://www.agilent.com>, enter N5242-90007 in the search field.

Service information can be found in the N5242A Agilent Technologies 2-Port and 4-Port PNA Microwave Network Analyzers (10 MHz–26.5 GHz) Service Guide (part number N5242-90001). This document can be found using the our web site at <http://www.agilent.com/find/pna/documents>. In “Other Products & Service,” select PNA Series Service & Support > Service Documentation and select N5242A Service Guide PDF. Replacement Parts are listed in Chapters 6 & 7.

The Agilent Technologies PNA Series Microwave Network Analyzers N5242A, will display Options H85. The Option H85 deletes bias tees from the N5242A-219 or N5242A-419 option. Service software is available for servicing the N5242A at local service centers.

Follow the Service Guide instructions for all repair, replacement procedures, tests and adjustments.

## Source Attenuator Operational Check

Firmware Revision A.07.50.20 or higher must be used for the N5242A Option H85.

## Replaceable Parts

**NOTE** Special options are built to order, so long lead times may be encountered when ordering replacement parts.

Reference Designator	PNA	Description	Agilent Part Number
<b>Add:</b>			
W11	N5242A-200	RF Cable: Port 1 CPLR THRU to A29 Test Port 1 Coupler	N5242-20111
W24	N5242A-200/029	RF Cable: Port 2 CPLR THRU to A32 Test Port 2 Coupler	N5242-20112
W12	N5242A-400	RF Cable: Port 1 CPLR THRU to A29 Test Port 1 Coupler	N5242-20055
W16	N5242A-400	RF Cable: Port 3 CPLR THRU to A30 Test Port 3 Coupler	N5242-20059
W24	N5242A-400/029	RF Cable: Port 2 CPLR THRU to A32 Test Port 2 Coupler	N5242-20063
W20	N5242A-400	RF Cable: Port 4 CPLR THRU to A31 Test Port 4 Coupler	N5242-20064
	N5242A-200/029	RF Cable: CPLR THRU to Switch, Port 1	N5242-20145
	N5242A-400/029	RF Cable: CPLR THRU to Switch, Port 1	N5242-20144
<b>Delete:</b>			
A38/A41	N5242A-219	Bias-tee with cable	5086-7239
A38/A39/A40/A41	N5242A-419	Bias-tee with cable	5086-7239
W73	All	RF Cable: Port 1 CPLR THRU to A38 Test Port 1 Bias-Tee	N5242-20039
W74	N5242A-219	RF Cable: A38 Test Port 1 Bias-Tee to A29 Test Port 1 Coupler	N5242-20115
W74	N5242A-419	RF Cable: A38 Test Port 1 Bias-Tee to A29 Test Port 1 Coupler	N5242-20022
W85	All	RF Cable: Port 2 CPLR THRU to A41 Test Port 2 Bias-Tee	N5242-20045
W86	N5242A-219	RF Cable: A41 Test Port 2 Bias-Tee to A32 Test Port 2 Coupler	N5242-20108
W86	N5242A-419	RF Cable: A41 Test Port 2 Bias-Tee to A32 Test Port 2 Coupler	N5242-20023
W77	N5242A-419	RF Cable: Port 3 CPLR THRU to A39 Test Port 3 Bias-Tee	N5242-20026
W78	N5242A-419	RF Cable: A39 Test Port 3 Bias-Tee to A30 Test Port 3 Coupler	N5242-20021

**Replaceable Parts**

<b>Reference Designator</b>	<b>PNA</b>	<b>Description</b>	<b>Agilent Part Number</b>
W81	N5242A-419	RF Cable: Port 4 CPLR THRU to A40 Test Port 4 Bias-Tee	N5242-20027
W82	N5242A-419	RF Cable: A40 Test Port 4 Bias-Tee to A31 Test Port 4 Coupler	N5242-20024
W11	N5242A-200/029	RF Cable: Port 1 CPLR THRU to A29 Test Port 1 Coupler	N5242-20111
W12	N5242A-400/029	RF Cable: Port 1 CPLR THRU to A29 Test Port 1 Coupler	N5242-20055



## Safety and Regulatory Information

### Introduction

Review this product and related documentation to familiarize yourself with safety markings and instructions before you operate the instrument. The documentation contains information and warnings that must be followed by the user to ensure safe operation and to maintain the product in a safe condition.

### Cleaning the Instrument

---

**WARNING** To prevent electrical shock, disconnect the instrument from mains before cleaning. Use a dry cloth or one slightly dampened with water to clean the external case parts. Do not attempt to clean internally.

---

### Connector Care and Cleaning

Cleaning connectors with alcohol shall only be done with the instrument power cord removed, and in a well ventilated area. Allow all residue alcohol moisture to evaporate and the fumes to dissipate prior to energizing the instrument.

---

**WARNING** Keep isopropyl alcohol away from heat, sparks, and flame. Store in a tightly closed container. It is extremely flammable. In case of fire, use alcohol foam, dry chemical, or carbon dioxide; water may be ineffective.

**Use isopropyl alcohol with adequate ventilation and avoid contact with eyes, skin, and clothing. It causes skin irritation, may cause eye damage, and is harmful if swallowed or inhaled. It may be harmful if absorbed through the skin. Wash thoroughly after handling.**

**In case of spill, soak up the spill with sand or earth. Flush spill area with water. Dispose of isopropyl alcohol in accordance with all applicable federal, state, and local environmental regulations.**

---

### Declaration of Conformity

For a copy of the manufacturer's Declaration of Conformity for this apparatus, contact your local Agilent Technologies office or sales representative. Refer to [“Contacting Agilent” on page 41](#).

### Statement of Compliance

This instrument has been designed and tested in accordance with IEC Publication 1010, Safety Requirements for Electronic Measuring Apparatus, and has been supplied in a safe condition. The instruction documentation contains information and warnings which must be followed by the user to ensure safe operation and to maintain the instrument in a safe condition.

## General Safety Considerations

### Safety Earth Ground

---

**WARNING** This is a Safety Class I product (provided with a protective earthing ground incorporated in the power cord). The mains plug shall only be inserted in a socket outlet provided with a protective earth contact. Any interruption of the protective conductor, inside or outside of the instrument, will make the instrument dangerous. Intentional interruption is prohibited.

---

### Before Applying Power

Verify that the product is configured to match the available main power source. If this product is to be powered by autotransformer, make sure the common terminal is connected to the neutral (grounded) side of the ac power supply.

Cautions applicable to this instrument.

---

**CAUTION** Always use the three-prong ac power cord supplied with this instrument. Failure to ensure adequate earth grounding (by not using this cord) can cause instrument damage.

---

---

**CAUTION** This product is designed for use in Installation Category II and Pollution Degree 2 per IEC 61010 Second Edition and 664 respectively.

---

---

**CAUTION** This instrument has autoranging line voltage input; be sure the supply voltage is within the specified range.

---

---

**CAUTION** Ventilation Requirements: When installing the instrument in a cabinet, the convection into and out of the instrument must not be restricted. The ambient temperature (outside the cabinet) must be less than the maximum operating temperature of the instrument by 4 °C for every 100 watts dissipated in the cabinet. If the total power dissipated in the cabinet is greater than 800 watts, forced convection must be used.

---

## Servicing

Warnings applicable to this instrument.

---

**WARNING** For continued protection against fire hazard replace line fuse only with same type and rating: Fuse 3.15A/250V, Part Number 2110-0655  
The use of other fuses or material is prohibited.

---

---

**WARNING** This is a Safety Class I product (provided with a protective earthing ground incorporated in the power cord). The mains plug shall be inserted only into a socket outlet provided with a protective earth contact. Any interruption of the protective conductor, inside or outside the product is likely to make the product dangerous. Intentional interruption is prohibited.

---

---

**WARNING** These servicing instructions are for use by qualified personnel only.

---

---

**WARNING** The opening of covers or removal of parts is likely to expose dangerous voltages. Disconnect the instrument from all voltage sources while it is being opened.

---

---

**WARNING** This product is designed for use in Installation Category II and Pollution Degree 2 per IEC 61010-1: 2001.

---

---

**WARNING** No operator serviceable parts inside. Refer servicing to qualified personnel.

---

---

**WARNING** If this product is not used as specified, the protection provided by the equipment could be impaired. This product must be used in a normal condition (in which all means for protection are intact) only.

---

## Regulatory Information

This section contains information that is required by various government regulatory agencies.

### Instrument Markings



The instruction documentation symbol. The product is marked with this symbol when it is necessary for the user to refer to the instructions in the documentation.



This symbol indicates that the instrument requires alternating current (ac) input.



This symbol indicates separate collection for electrical and electronic equipment, mandated under EU law as of August 13, 2005. All electric and electronic equipment are required to be separated from normal waste for disposal (Reference WEEE Directive, 2002/96/EC).



This symbol indicates that the power line switch is ON.



This symbol indicates that the power line switch is in the STANDBY position.



This symbol indicates that the power line switch is in the OFF position.



This symbol is used to identify a terminal which is internally connected to the product frame or chassis.



The CE mark is a registered trademark of the European Community. (If accompanied by a year, it is when the design was proven.)



The CSA mark is a registered trademark of the Canadian Standards Association. This instrument complies with Canada: CSA 22.2 No. 000000061010-1, Second Edition.



This is a symbol of an Industrial Scientific and Medical Group 1 Class A product.



This is a marking to indicate product compliance with the Canadian Interference-Causing Equipment Standard (ICES-001).



Direct Current.



This is a required mark signifying compliance with an EMC requirement. The C-Tick mark is a registered trademark of the Australian Spectrum Management Agency.



China RoHS regulations include requirements related to packaging, and require compliance to China standard GB18455-2001.



This symbol indicates compliance with the China RoHS regulations for paper/fiberboard packaging.

### **Compliance with Canadian EMC Requirements**

This ISM device complies with Canadian ICES-001.  
Cet appareil ISM est conforme a la norme NMB du Canada.

### **Compliance with German FTZ Emissions Requirements**

This product complies with the German FTZ 526/527 Radiated Emissions and Conducted Emission requirements.

### **Compliance with German Noise Requirements**

This is to declare that this instrument is in conformance with the German Regulation on Noise Declaration for Machines (Laermangabe nach der Maschinenlaermrrordnung-3. GSGV Deutschland).

<b>Acoustic Noise Emission/Geraeuschemission</b>	
LpA<70 dB	Lpa<70 dB
Operator Position	am Arbeitsplatz
Normal Operation	normaler Betrieb
per ISO 7779	nach DIN 45635 t. 19

---

## Electrostatic Discharge Protection

Protection against electrostatic discharge (ESD) is essential while removing assemblies from or connecting cables to the network analyzer. Static electricity can build up on your body and can easily damage sensitive internal circuit elements when discharged. Static discharges too small to be felt can cause permanent damage. To prevent damage to the instrument:

- *always* have a grounded, conductive table mat (9300-0797) in front of your test equipment.
- *always* wear a grounded wrist strap (9300-1367) with grounding cord (9300-0980), connected to a grounded conductive table mat, having a 1 M $\Omega$  resistor in series with it, when handling components and assemblies or when making connections.
- *always* wear a heel strap (9300-1126) when working in an area with a conductive floor. If you are uncertain about the conductivity of your floor, wear a heel strap.
- *always* ground yourself before you clean, inspect, or make a connection to a static-sensitive device or test port. You can, for example, grasp the grounded outer shell of the test port or cable connector briefly.
- *always* ground the center conductor of a test cable before making a connection to the analyzer test port or other static-sensitive device. This can be done as follows:
  1. Connect a short (from your calibration kit) to one end of the cable to short the center conductor to the outer conductor.
  2. While wearing a grounded wrist strap, grasp the outer shell of the cable connector.
  3. Connect the other end of the cable to the test port and remove the short from the cable.

**Figure 26** ESD Protection Setup

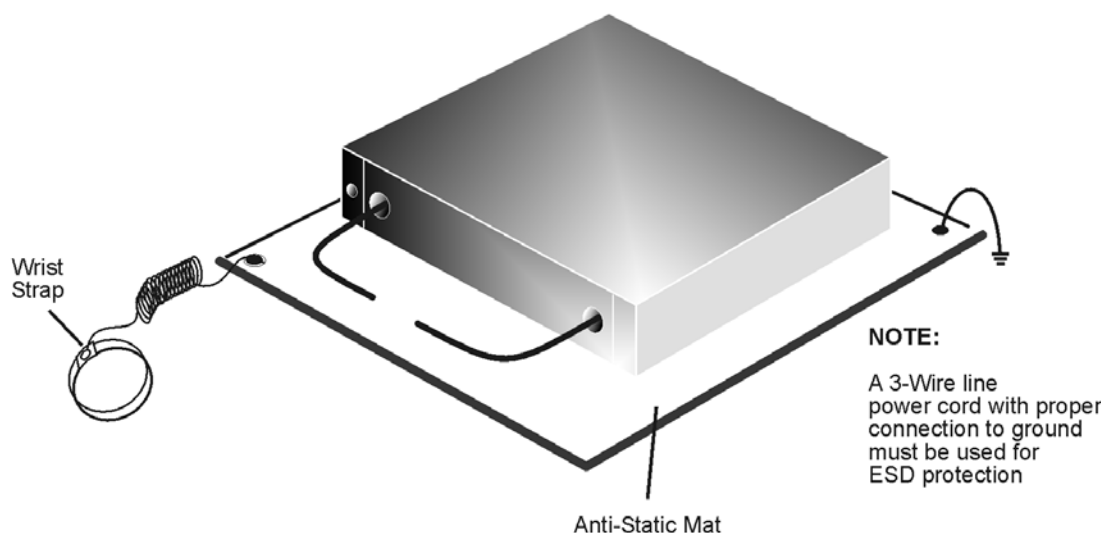

ku310b

---

## Agilent Support and Assistance

### Service and Support Options

The analyzer's standard warranty is a one-year return to Agilent Technologies service warranty.

See “[Service Information](#)” on page 32 for PNA information.

---

**NOTE** There are many other repair and calibration options available from the Agilent Technologies support organization. These options cover a range of service agreements with varying response times. Contact Agilent for additional information on available service agreements for this product. Refer to “[Contacting Agilent](#)” on page 41.

---

### Contacting Agilent

Assistance with test and measurements needs and information or finding a local Agilent office are available on the Web at:

<http://www.agilent.com/find/assist>

If you do not have access to the Internet, please contact your Agilent field engineer.

---

**NOTE** In any correspondence or telephone conversation, refer to the Agilent product by its model number and full serial number. With this information, the Agilent representative can determine whether your product is still within its warranty period.

---

### Shipping Your Analyzer to Agilent for Service or Repair

---

**IMPORTANT** Agilent Technologies reserves the right to reformat or replace the internal hard disk drive in your analyzer as part of its repair. This will erase all user information stored on the hard disk. It is imperative, therefore, that you make a backup copy of your critical test data located on the analyzer's hard disk before shipping it to Agilent for repair.

---

If you wish to send your network analyzer to Agilent Technologies for service or repair:

- Include a complete description of the service requested or of the failure and a description of any failed test and any error message.
- Ship the analyzer using the original or comparable antistatic packaging materials.
- Contact Agilent for instructions on where to ship your analyzer.

